

Henry P. Roybal  
Commissioner, District 1

Miguel M. Chavez  
Commissioner, District 2

Robert A. Anaya  
Commissioner, District 3



Kathy Holian  
Commissioner, District 4

Liz Stefanics  
Commissioner, District 5

Katherine Miller  
County Manager

**DATE:** July 16, 2015

**TO:** County Development Review Committee

**FROM:** Jose E. Larrañaga, Development Review Team Leader *JEL*

**VIA:** Penny Ellis-Green, Growth Management Director *PEG*  
Vicki Lucero, Building and Development Services Manager *VL*

**FILE REF.:** CDRC CASE # Z/PDP/FDP 15-5130 Ashwin Stables

**ISSUE:**

Don Altshuler, Applicant, James W. Siebert & Associates, Agent, request Master Plan Zoning, Preliminary and Final Development Plan approval to allow an Equestrian Facility on 2.71 acres  $\pm$ . The property is located within Section 4, Township 17 North, Range 9 East, (Commission District 2) at 10 Heartstone Drive.

**Vicinity Map:**

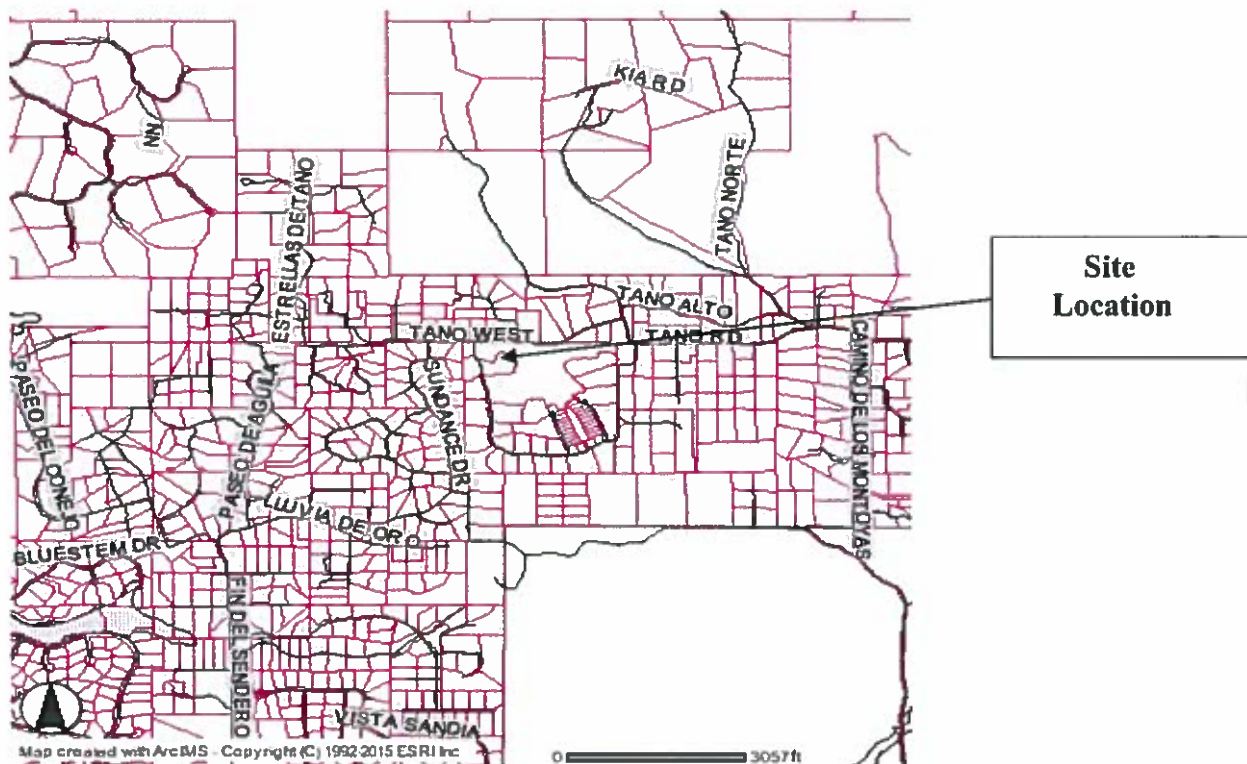

NBD-1

## SUMMARY:

The Applicant requests Master Plan Zoning, Preliminary & Final Development Plan approval to allow an Equestrian Facility on 2.71 acres in conformance with Ordinance No. 1998-15 (Other Development) and Santa Fe County Ordinance 1996-10, the Santa Fe County Land Development Code (Code). The facility consists of a 706 square foot residence located above a 2,250 square foot-4 horse barn, a 1,960 square foot-8 horse stable, a 648 square foot-4 horse stable, a 1,035 square foot hay barn, a 9,946 square foot covered arena and a maximum of 16 horses to be boarded on the site. The structures are existing and were permitted and utilized by the Applicant for personal use. The proposed facility is currently located within a 7.74 acre parcel. The Applicant proposes to sub-divide the 7.74 acre parcel to create 3 lots consisting of two 2.5 acre residential lots and a 2.71 acre parcel to be utilized for the Equestrian Facility.

The Applicant's Report states:

The equestrian use that is shown in this request for Master Plan and Development Plan approval will remain as it has existed for the last 15 years. Until recently Mr. Altshuler kept four of his family horses at this site. Mr. Altshuler is no longer able to ride and the horses have been sold. Some of the residents who use to board horses no longer do so. If boarding of horses from outside the subdivision is not possible, the equestrian use is not financially feasible. The use list for the property is limited to an equestrian facility including boarding of horses and its ancillary structures and activities, such as the small residence for the stall keeper and training and instruction of riders.

Ordinance 1998-15, Section 8.1 states, "subject to the requirements of this Section, all uses not otherwise regulated by the Code are permitted anywhere in the County provided a request for zoning approval is granted per Article III..."

Article V, § 5.2.1.b states, "a master plan is comprehensive in establishing the scope of a project, yet is less detailed than a development plan. It provides a means for the County Development Review Committee and the Board to review projects and the sub-divider to obtain concept approval for proposed development without the necessity of expending large sums of money for the submittals required for a preliminary and final plat approval."

Article V, § 7.1.3.a (Preliminary Development Plans) states, "a preliminary development plan may be only a phase or portion of the area covered by an approved master plan, so long as the preliminary development plan substantially conforms to the approved master plan."

Article V, § 7.2 (Final Development Plan) states:

A final development plan conforming to the approved preliminary plan and approved preliminary plat, if required, and containing the same required information shall be submitted. In addition, the final development plan shall show, when applicable, and with appropriate dimensions, the locations and size of buildings, heated floor area of buildings, and minimum building setbacks from lot lines or adjoining streets. Documents to be submitted at this time are: proof of ownership including necessary title documents,

NBD-2

articles of incorporation and by-laws of owners' association; required disclosure statements; final engineering plans and time schedule for grading, drainage, and all improvements including roads, water system, sewers, solid waste, utilities; engineering estimates for bonding requirements; development agreements; and final subdivision plats, if required.

The owner of the property acquired the property by warranty deed recorded as Instrument # 1420118 in the Santa Fe County Clerk's records dated February 14, 2006. James W. Siebert & Associates is authorized by the property owner to pursue the request for Master Plan Zoning, Preliminary and Final Development Plan approval to allow an Equestrian Facility on a 2.71 acre ± site, as evidenced by a copy of the written authorization contained in the record (Exhibit 9).

Notice requirements were met as per Article II § 2.4.2, of the Code. In advance of a hearing on the Application, the Applicant provided a certification of posting of notice of the hearing, confirming that public notice posting regarding the Application was made for twenty-one days on the property, beginning on June 25, 2015. Additionally, notice of hearing was published in the legal notice section of the Santa Fe New Mexican on June 25, 2015, as evidenced by a copy of that legal notice contained in the record. Receipts for certified mailing of notices of the hearing were also contained in the record for all adjacent property owners (Exhibit 10).

This Application was submitted on April 10, 2015.

**Building and Development Services staff have reviewed this project for compliance with pertinent Code requirements and have found that the facts presented support this request: the application is comprehensive in establishing the scope of the project; the proposed Preliminary Development Plan substantially conforms to the proposed Master Plan; the Final Development Plan conforms to the Code requirements for this type of use; and the Application satisfies the submittal requirements set forth in the Code.**

**The review comments from State Agencies and County staff have established findings that the Application is in compliance with state requirements, Ordinance 1998-15, Article V, § 5.2 Master Plan Procedure, Article V, § 7.1 Preliminary Development Plan and Article V, § 7.2 Final Development Plan of the Code.**

**APPROVAL SOUGHT:** Master Plan Zoning, Preliminary & Final Development Plan approval to allow an Equestrian Facility on 2.71 acres.

**GROWTH MANAGEMENT AREA:** SDA-1.

**HYDROLOGIC ZONE:** Basin Hydrologic Zone, minimum lot size in this area is 2.5 acres with recorded water restrictive covenants of 0.25 acre feet.

NBD-3

**ARCHAEOLOGIC ZONE:**

An Archeological Survey was conducted on 140 acres for the Heartstone Subdivision in 2002. The New Mexico Historic Preservation Division reviewed the Application and states the following, "there are no historic properties listed on the State Register of Cultural Properties or the National Register of Historic Place within the project parcel. One archaeological site appears to be within or very near the project area; however, this site was determined to be ineligible for listing in the State or National Register. Because this site is not significant, the proposed project will have No Effect on Historic Properties."

**ACCESS AND TRAFFIC:**

The primary access to the project is via Heartstone Drive. Heartstone Drive is a 24 foot wide, two lane road with an asphalt surface. The distance from the equestrian use driveway intersection at Heartstone Drive to Tano West is 920 feet. Tano West is a paved two lane roadway which is designated as County Road 85A. A Site Threshold Assessment form has been prepared as required by the New Mexico Department of Transportation (NMDOT), District Five, as part of the NMDOT review of projects in Santa Fe County. Since the use is existing the additional traffic would be limited to the horses that might be stabled at the site from clients that are not residents of the Heartstone Subdivision. The horse trainer and her assistant live on the property on an adjoining lot and, therefore, create no greater use than a residential dwelling, and actually less so, since during the AM and PM periods they are generally working at the site.

Santa Fe County Public Works Department has reviewed the submittal and supports the Application. Public Works did not require a TIA for this Development.

NMDOT reviewed the Application and has determined that this development will not impact any State Transportation System.

**FIRE PROTECTION:**

The closest fire station is located off Las Campanas Drive at 3 Arroyo Calabazas approximately 4.1 miles from this site. This fire station is manned on a full time basis. The Agua Fria fire station that is also manned on a 24 hour basis is located on 58 Caja del Oro Grant Road (CR 62) approximately 7.7 miles from the site. There is currently 60,000 gallons of water storage available in the Heartstone development and fire hydrants have been installed

NBD-4

throughout the residential subdivision. The existing water system serving the subdivision will be extended within 1000 feet of the fire staging area for this site.

Santa Fe County Fire Prevention Division reviewed the Application and stated the following: a fire hydrant shall be located within 1000 feet of the fire staging area; driveway/fire access shall not exceed 11% slope and shall have a minimum 28' inside radius on curves; shall comply with Article 1, § 103.3.2-New Construction and Alterations of the 1997 Uniform Fire Code, inclusive to all subsections and current standards, practice and rulings of the Santa Fe County Fire Marshal." The existing driveway complies with these standards.

**WATER SUPPLY:**

The existing well is located on Lot A-1C-1 which will serve all three proposed lots. The well was permitted by the Office of the State Engineer (OSE) with an assigned well number of RG76968. There currently is not a meter on this well. Meters, one for each lot, shall be installed and meter readings shall be submitted to the OSE and the County Hydrologist on a quarterly basis. The Applicant has submitted a water budget, establishing that the yearly water use will not exceed .25 afy. Water restrictive covenants, restricting the water use to 0.25 acre feet per year, shall be recorded along with the Final Development Plan.

The County Hydrologist reviewed the water budget submitted by the Applicant and states the following,

the proposed Ashwin Stable lot falls under non-residential development, in which the project as a whole uses up to 0.25 acre-foot of water annually. The water budget indicates that the amount of water to be used for the facility will be .226 afy. The Applicant proposes to provide water to the equestrian facility (Tract A1C-1C), which includes a single residential unit, an adjoining residential unit (Tract A1C-1B) and a third residential lot (A1C-1A) via an existing domestic well permitted by the OSE. The well is identified by OSE as RG-76968. The property lies within the Basin Hydrologic Zone. Santa Fe County previously approved a lot split administratively and limited water use to 0.75 acre-foot per year for the entire 7.746 acre property. Therefore, each lot will be limited to 0.25 acre-feet at time of Plat approval. Each lot owner will be required to read their individual meter monthly and submit those readings to

NBD-5

the County annually to ensure compliance with this requirement.

**LIQUID WASTE:**

An existing septic tank and leach field will serve the small residence above the barn and the few clients of the horse trainer utilizing the facilities in the residence. The existing septic system is approved and permitted by the New Mexico Environment Department (NMED).

NMED reviewed the Application and states that the existing on-site liquid waste disposal system is adequate for the proposed development.

**SOLID WASTE:**

Solid waste will be collected on a weekly basis by a private solid waste collection company that currently services the residential subdivision. Horse manure will be removed on a weekly basis and taken to the regional landfill for burial.

**FLOODPLAIN & TERRAIN MGMT:**

The site contains slopes, from the north to the south, of 0-20%. All cut slopes are less than 2:1 and all fill slopes are 3:1. The request is in conformance with Article VII, Section 3.4.2 (Terrain Management Plan).

The Applicant's proposal illustrates existing conditions and a proposed grading and drainage plan. The required amount of retainage required for runoff is 4,615 cubic feet. The amount of retainage provided is 25,000 cubic feet. Therefore, the proposal is in conformance with Article VII, Section 3.4.6 and Ordinance 2008-10 (Flood Damage Prevention and Stormwater Management).

**SIGNAGE AND LIGHTING:**

The Applicant does not propose any signage in this Application. Any future signage shall comply with Article VIII (Sign Regulations).

The Application does not illustrate any proposed or existing outdoor lighting in this Application. Any future outdoor lighting shall comply with Article III, Section, 4.4.4h (Outdoor Lighting Standards).

**EXISTING DEVELOPMENT:**

Existing structures consist of a 706 square foot residence located above a 2,250 square foot-4 horse barn, a 1,960 square foot-8 horse stable, a 648 square foot-4 horse stable, a 1,035 square foot hay barn and a 9,946 square foot covered arena.

NB10-6

**ADJACENT PROPERTY:**

The site is bordered to the north, east and south by designated open space. To the west the site is bordered by a residence owned by the Applicant.

**PARKING:**

The site plan illustrates a designated parking area of 10 parking spaces. An area for horse trailer parking and an area for unloading feed are delineated on the site plan. All parking areas shall be clearly marked. Parking of vehicles outside of the designated area shall be discouraged to minimize erosion and dust on the site. Staff has determined that the parking element of the Application meets the criteria set forth in Article III, Section 9 (Parking Requirements).

**LANDSCAPING:**

The Applicant submitted a landscaping plan illustrating the existing vegetation on the site. The existing vegetation is adequate, therefore the landscape element of the development meets the intent of the landscape standards of Article III, Section 4.4.4.f 4 Landscaping Plan of the Code.

**RAINWATER HARVESTING:**

The Applicant submitted a water harvesting plan consisting of two existing 5,000 gallon storage tanks and a water budget to reduce the cistern size from 23,758 gallons to 10,000 gallons. The captured rain water will be utilized for the horses (drinking, bathing and washing of facilities) in an effort to reduce water used from the well. Therefore the water harvesting element of the request meets the intent of Ordinance No. 2008-4.

**AGENCY REVIEW:**

<u>Agency</u>	<u>Recommendation</u>
NMOSE	No Formal Opinion
NMDOT	Approval
NMED	Approval
NMDHP	Approval
County Fire	Conditional Approval
County PW	Approval
County Hydrologist	Approval

**STAFF RECOMMENDATION:**

**Approval of Master Plan Zoning, Preliminary and Final Development Plan to allow an Equestrian Facility on 2.71 acres subject to the following staff conditions:**

1. The Applicant shall comply with all review agency comments and conditions as per Article V, § 7.1.3.c.

NB10-7

2. Master Plan, Preliminary and Final Development Plan with appropriate signatures, shall be recorded with the County Clerk as per Article V, § 5.2.5.
3. Horse manure shall be removed on a weekly basis and taken to the regional landfill for burial. This shall be noted on the Master Plan/Development Plan.
4. Maximum amount of horses to be stabled at facility shall not exceed 16. This shall be noted on the Master Plan/Development Plan.
5. Water restrictive covenants, restricting the water use to 0.25 acre feet per year, shall be recorded along with the Final Development Plan. Meter readings shall be submitted to the County Hydrologist on a quarterly basis. If the water use exceeds 0.25 acre feet per year the number of horses allowed to be stabled on the facility shall be reduced. This shall be noted on the Master Plan/Development Plan.

**EXHIBITS:**

1. Applicants Report
2. Drawings
3. Ordinance 1998-15 (Other Development)
4. Article V, § 5 (Master Plan Procedures)
5. Article V, § 7 (Preliminary Development Plans)
6. Article V, § 7.2 (Final Development Plan)
7. Aerial Photo of Property
8. Agency Reviews and Comments
9. Warranty Deed and Letter of Authorization
10. Legal Notice
11. Letters of Concern
12. Letters of support

NBD-8





**ASHWIN STABLES**

**MASTER PLAN/PRELIMINARY & FINAL  
DEVELOPMENT PLAN**

**REPORT**

**PREPARED FOR DON ALTSHULER**

**PREPARED BY**

**JAMES W. SIEBERT & ASSOCIATES INC.**

**APRIL 10, 2015**



NBD-9

# TABLE OF CONTENTS

---

Introduction and Background Information	2
Project Location	2
Ownership and Legal Lot	4
Development Request	4
Existing Conditions and Adjoiners	4-5
Fire Protection	5
Access	6
Environmental Evaluation	6-7
Project Description	7-8
<i>Signs &amp; Lighting</i>	7
<i>Solid Waste</i>	7
<i>Water Supply</i>	7
<i>Water Budget</i>	8
<i>Liquid Waste</i>	8

## Figures

Figure 1:	Vicinity Map
Figure 2:	Adjoiners Map

## APPENDICES

Appendix A	Proposed Land Division Plat
Appendix B	Warranty Deed & Plat
Appendix C	Site Threshold Assessment
Appendix D	Approved Drainage Plan
Appendix E	FEMA Floodplain Map
Appendix F	Well Permit
Appendix G	Liquid Waste Permit

NB0-10

## Introduction and Background Information

The property that is the subject of this application was previously approved as an administrative lot split creating four lots to establish the boundary of the Heartstone Subdivision (aka Canterbury Subdivision). The equestrian structures on the subject property were built for use by the current owners of the property and for the residents of the Heartstone Subdivision. After being injured from falling off a horse, Mr. Altshuler, who owned several horses decided he would no longer use the facility and at that point leased the property to his trainer for boarding and training of her own horses. At the time the equestrian facility was built it included stalls for 16 horses, a small residence for the person taking care of the horses, an indoor riding arena, an outdoor riding corral and a hay barn.

These facilities were permitted and constructed in the time period from 2001-2005.

## Project Location

The equestrian facility is currently located on a 7.746 acre lot. In order to define the size of the equestrian center a subdivision plat has been prepared that identifies the site of the equestrian center as a 2.711 acre lot. A description of the lot as prepared by Paramount Surveys is included in the report as Appendix A. The subject property is located to the south of Tano West, which is also designated as County Road 84A. The access road to the equestrian use is Hearstone Drive. This road was constructed as part of the Heartstone Subdivision. Don Altshuler, the developer of Heartstone will continue to retain ownership of the equestrian facility lot. The equestrian use is located at the entry to the residential dwelling on future Lot A1C-1B and is largely surrounded by open space that was platted and dedicated at the time of the approval of the original development plan. Figure 1 is a description of the location of the equestrian use relative to the public and private roads in the area.

# SITE

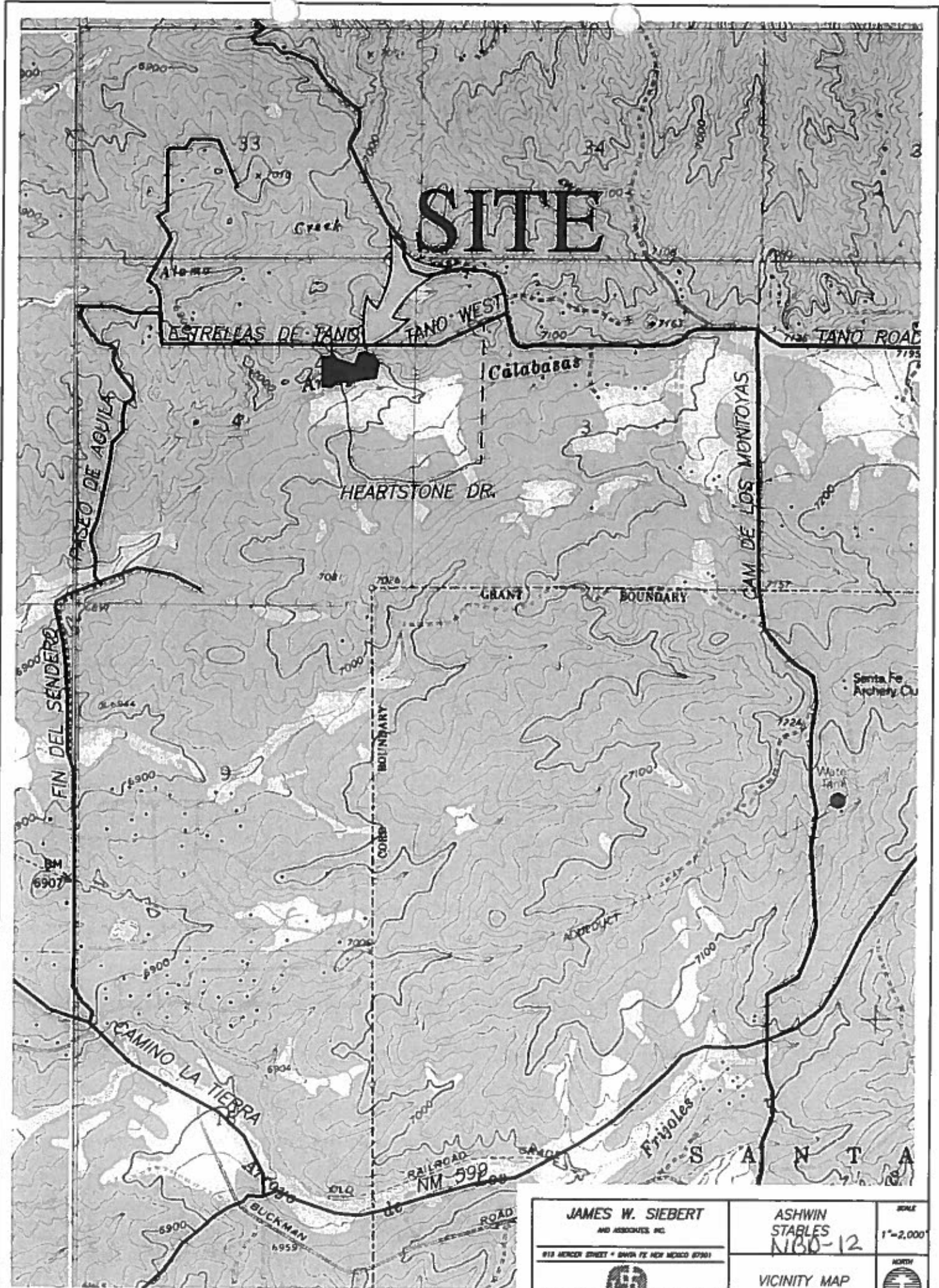

**JAMES W. SIEBERT**  
AND ASSOCIATES, INC.  
913 HENCKES STREET • SANTA FE, NEW MEXICO 87501  
(505) 962-0288  FAX (505) 966-7213

SCALE  
1"=2,000'  
NORTH  
  
**ASHWIN STABLES**  
N180-12  
VICINITY MAP

### Ownership and Legal Lot of Record

The property is owned by the Altshuler LLC, a company own by Don and Jean Altshuler and their three children. The 7.746 acre lot is identified by a plat recorded in Book 677 Page 29 of the records of the Santa Fe County Clerk. A survey has been prepared which limits the equestrian use to 2.711 acres. This same survey also creates two other residential lots that were part of the Heartstone master plan. There is a house on Tract A1C-1A, where the trainer for the equestrian use currently resides. Tract A1C-1B also has a residential dwelling originally occupied by Don and Jean and now rented. The deed for the property and a reduction of the current plat creating legal lot of record is provided in this report as Appendix B.

### Development Request

An "Other Development" designation is requested for the proposed use. Article III, Section 8 of the Land Development Code, therefore, is the development request applicable to this application. "Other Development" is generally used for less intensive projects that do not fit into the usual land use categories defined by the Land Development Code.

Because this is an existing use and has been for the last 15 years the development request includes a master plan, preliminary and final development plan to be considered by the County Development Review Committee and the Board of County Commissioners.

### Existing Conditions and Adjoiners

This use is surrounded on three sides by open space which is part of the Heartstone development. The residence in closest proximity to the equestrian use is owned by Don Altshuler. The tract of land that is across Heartstone road has a residential dwelling unit and is also owned by Altshuler LLC. The location of the equestrian and the adjoining land uses is described on the existing conditions found on P-2 of the plan set.

The existing buildings located on the equestrian use consist of the following:

Lot Size:

4 horse barn and residence above:	Stable 2,250 sq. ft. Residence 706 sq.ft.
8 stable structure (stable B):	1,960 sq. ft.
Covered arena:	9,943 sq. ft.
4 stable structure (stable A):	648 sq. ft.
Hay barn:	1,035 sq. ft.
Lot coverage for all structures:	13% (15,836 sq.ft.) of 2.71 acre lot

**Fire Protection**

The closest fire station is located off Las Campanas Drive at 3 Arroyo Calabasas approximately 4.1 miles from this site. This fire station is manned on a full time basis. The Agua Fria fire station that is also manned on a 24 hour basis is located on 58 Caja del Oro Grant Road (CR 62) approximately 7.7 miles from the equestrian use.

A site visit was conducted by the County Fire Marshal to assess the measures needed to provide adequate fire protection to this use. There is currently 60,000 gallons of storage available in the Heartstone development and fire hydrants have been constructed throughout the residential subdivision. It was agreed as a result of the site visit by the Fire Marshal that the existing water system serving the subdivision would be extended to a point shown on the fire protection plan which would be located within 1000 feet of the fire staging area, also shown on the fire protection plan.

There is an existing loop road that extends to the parking area and one of the stables crossing the drainage and returning to Heartstone Road. The loop road serves as the fire access instead of a dead-end turnaround.

Heartstone Drive, which serves as the primary access to the subject use is a 24 foot, two lane road with an asphalt surface. The distance from the equestrian use driveway intersection at Heartstone Road to Tano West is 920 feet. Tano West is a paved two lane roadway which is designated as County Road 85A.

## Access

A Site Threshold Assessment form has been prepared as required by NMDOT, District Five, as part of the NMDOT review of projects in Santa Fe County. Since the use is existing the additional traffic would be limited to the horses that might be stabled at the site from clients that are not residents of the Heartstone Subdivision. The horse trainer and her assistant live on the property and adjoining lot and, therefore, create no greater use than a residential dwelling, and actually less so, since during the AM and PM periods they are generally working at the site. The completed Site Threshold Assessment form is found in Appendix C.

## Environmental Evaluation

### Drainage

There is a platted drainage easement for the Arroyo Calabasas that is located on the most southern end of the property and was previously platted as shown on the plat of record in Book 492 Page 004. The drainage improvements and the engineering calculations for the drainage that were prepared and approved in 2000 are provided in a reduced form in Appendix D.

The drainage structures improvements to the drainage were also approved by the Army Corps of Engineers. A copy of the approved Nationwide permit has been requested and will be submitted upon delivery from the Army Corps of Engineers. The storm water retention requirements were satisfied as part of the improvements for the entire subdivision.

### Flood Plain

The subject property lies outside the limits of the 500 year flood plain as shown on the FEMA floodplain map in Appendix E.

### Terrain

A site for the indoor (covered) arena was graded into the hill in order to lower the profile of the largest structure within the equestrian area. No grading will take place within the lot as a result of approval of this application. The structures that are existing within the 2.711 acre tract is the total of development that will occur if this application is approved.

A slope analysis, soils evaluation and description of existing vegetation has not been submitted with the application since no further disturbance of the site is proposed if the request is approved.

## **Project Description**

The equestrian use that is shown in this request for master plan and development plan approval will remain as it has existed for the last 15 years. Until recently Mr. Altshuler kept four of his family horses at this site. Mr. Altshuler is no longer able to ride and the horses have been sold. Some of the residents who used to board horses no longer do so. If boarding of horses from outside the subdivision is not possible, the equestrian use is not financially feasible.

The use list for the property is limited to an equestrian facility including boarding of horses and its ancillary structures and activities, such as the small residence for the stall keeper and training and instruction of riders.

No more than 16 horses will be kept on the property at any given time, unless the property owner provides the County with a geo-hydrologic study that proves additional water use above the .25 acre foot restriction. It should be pointed out that the water budget assumed horses to be stabled for 365 days out of the year. In practice the number of horses varies with several horses only being stabled for a few months.

### Signs and Lighting

No identification signs are proposed with this application. No outdoor lighting is proposed for the property. It is the desire of the owner to maintain a low profile and have the least impact to the existing residents from this modification to the operation of the equestrian facilities at this site.

### Solid Waste

The minimal personal solid waste that is generated by this use is collected on a weekly basis by the same private solid waste collection company that currently services the residential subdivision. Horse manure is removed on a weekly basis and taken to the regional landfill for burial. A site inspection demonstrated that this is an exceptionally clean operation.

### Water Supply

There is a well located on Lot A-1C-1 that serves all three lots. This well is limited to .75 acre feet as a shared well for all three lots. This well has been permitted by the Office of the State Engineer with an assigned well number of RG76968. The well permit from the OSE is enclosed as Appendix F. There currently is not a meter on this well. The applicant understands that a meter will have to be installed and meter readings submitted to the OSE on a quarterly basis. The stables and one person residence will be limited to .25 acre feet per year.



## Water Budget

### Rain water capture

Size of tanks: (2) existing 5,000 gal tanks = 10,000 gal storage  
 Roof area: 1,960, sq.ft  
 Annual rainfall, drought conditions: 9.46 inches

$9.46 \times 2.623 \times 1960 = 11,551$  gals x .90 evaporative loss = 10,396 gals of annual water capture

\*roof run-off used for horses.

Use	Gals/day	Days/year	Total gals/year
Stall keeper (1)	60	<sup>3</sup> 350	21,000
Horses (12)	<sup>4</sup> 13 gals/horse	365	56,940
Clients (4)	<sup>5</sup> 5gals/client	300	6,000
		Subtotal	83,940
		Less Rain Water Capture	-10,396
		<b>Grand total of water use</b>	<b>73,544 gals (.226 af/yr)</b>

### Liquid Waste

There is a septic tank and leach field that serves the small residence above the barn and the few clients of the horse trainer. The permit from NMED for the septic tank is included in this report as Appendix G. The location of the septic tank and leach field are shown on sheet 4 of the plan set. The liquid waste for this use is limited and will continue to be limited if Other Development zoning is approved for this property.

<sup>1</sup> Based on drought year

<sup>2</sup> Conversion of inches to gals/sq.ft.

<sup>3</sup> 15 days vacation or absence/year

<sup>4</sup> Based on average of 12 horses housed 365 days/year, based on experience by horse trainer 13/gals/day derived from OSE New Mexico Water Use by Categories

<sup>5</sup> Horse trainer and 3 clients/day

# ASHWIN STABLES MASTER PLAN, PRELIMINARY & FINAL DEVELOPMENT PLAN

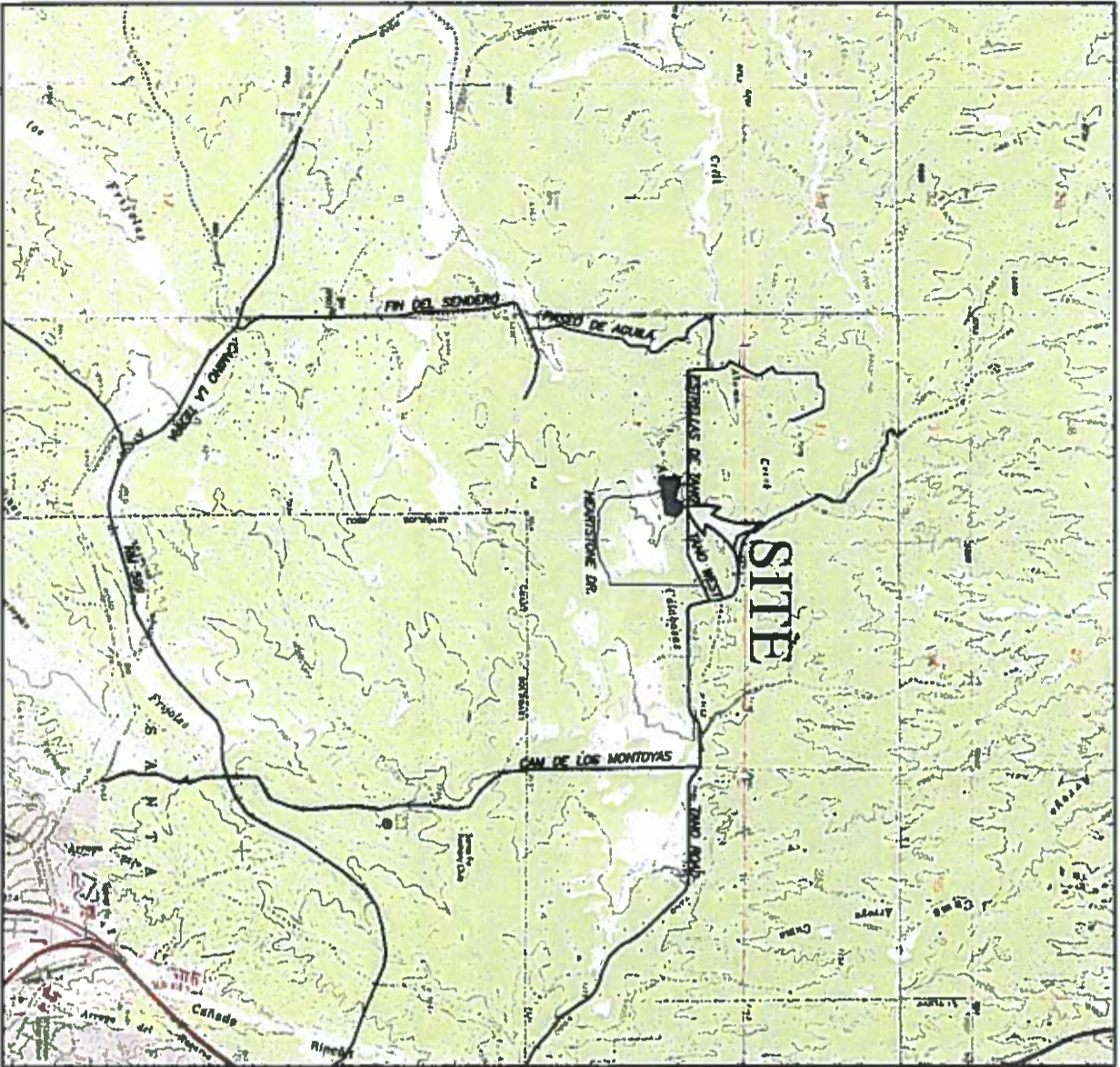

TOWNSHIP 17 N, RANGE 9 E, SECTION 4

**OWNERS:**

ASHWIN STABLES  
DON ALTSHULER  
22 PLANO ARBOLETO  
SANTA FE, NM 87506  
(505) 471-1183

**CONSULTANTS:**

JAMES W. SIEBERT AND ASSOCIATES  
PLANNING CONSULTANT  
915 MERCER STREET  
SANTA FE, NM 87505  
(505) 983-5588  
(505) 989-7313 FAX



**PURPOSE STATEMENT**  
TO RECOGNIZE AN EXISTING EQUESTRIAN USE AS "OTHER DEVELOPMENT"

CONSENT OF OWNER \_\_\_\_\_

DON ALTSHULER \_\_\_\_\_ DATE \_\_\_\_\_

INDEX TO SHEETS	
LIST OF SHEETS	SHEET NUMBER
PLANNING SHEETS	
COVER SHEET	P-1
EXISTING CONDITIONS	P-2
FIRE PROTECTION PLAN	P-3
MASTER PLAN, PRELIMINARY & FINAL DEVELOPMENT PLAN	P-4
BUILDING ELEVATIONS	P-5 & P-6
LANDSCAPE PLAN	P-7

**COUNTY**

APPROVED BY THE COUNTY DEVELOPMENT REVIEW COMMITTEE, OF SANTA FE COUNTY AT THEIR MEETING OF JUNE 24, 1997.

CORR. CHAIRPERSON \_\_\_\_\_ DATE \_\_\_\_\_  
 APPROVED BY THE BOARD OF COUNTY COMMISSIONERS, OF SANTA FE COUNTY AT THEIR MEETING OF \_\_\_\_\_ DATE \_\_\_\_\_  
 BEC. CHAIRPERSON \_\_\_\_\_ DATE \_\_\_\_\_  
 ATTESTED BY COUNTY CLERK \_\_\_\_\_ DATE \_\_\_\_\_  
 LAND USE ADMINISTRATOR \_\_\_\_\_ DATE \_\_\_\_\_  
 COUNTY TREE TENDER \_\_\_\_\_ DATE \_\_\_\_\_  
 PUBLIC WORKS DIRECTOR \_\_\_\_\_ DATE \_\_\_\_\_  
 RURAL ADDRESSING \_\_\_\_\_ DATE \_\_\_\_\_



VICINITY MAP  
1" = 1,000'

<b>JAMES W. SIEBERT</b> AND ASSOCIATES, INC. 915 MERCER STREET • SANTA FE, NEW MEXICO 87505 (505) 983-5588    Fax: (505) 989-7313		SCALE: AS SHOWN DRAWN BY: JWS CHECKED BY: JWS DATE: 2015		DATE: 2015 CHECKED BY: JWS DATE:		SHEET: P-1	
ASHWIN STABLES		COVER SHEET		SHEET: P-1		SHEET: P-1	

NB1D-18

SUNDANCE ESTATES SUBDIVISION  
BLOCK 1

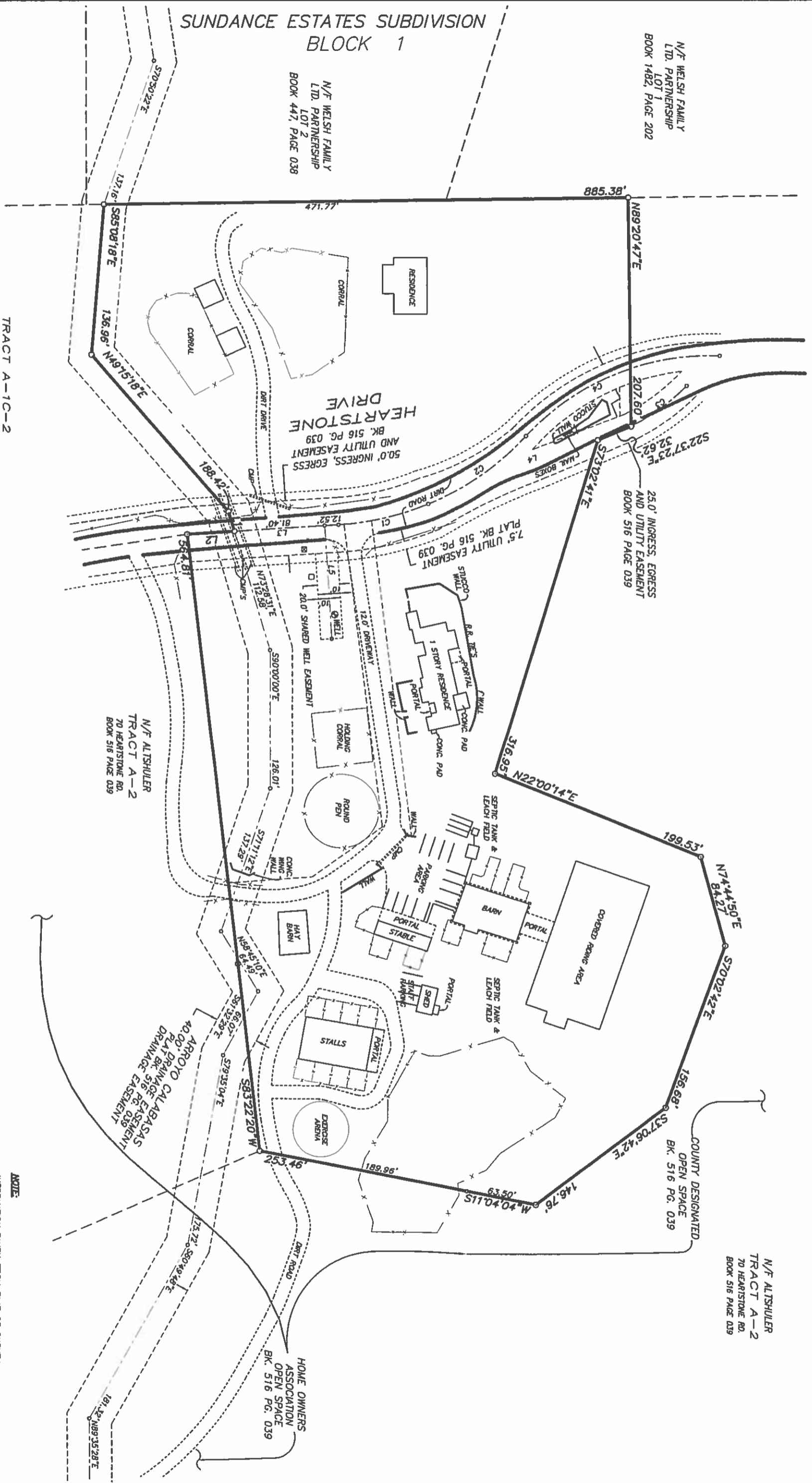

N/F WELSH FAMILY  
LTD. PARTNERSHIP  
LOT 1  
BOOK 1482, PAGE 202

N/F WELSH FAMILY  
LTD. PARTNERSHIP  
LOT 2  
BOOK 447, PAGE 038

N/F ALTSHULER  
TRACT A-2  
70 HEARTSTONE RD.  
BOOK 516 PAGE 039

N/F ALTSHULER  
TRACT A-2  
70 HEARTSTONE RD.  
BOOK 516 PAGE 039

TRACT A-1C-2

NOTE:  
INFORMATION TAKEN FROM PLAT OF SURVEY  
PREPARED BY PARAMOUNT SURVEY  
RECORDED AS BOOK 492, PAGE 004.

NBD-19

JAMES W. SIEBERT AND ASSOCIATES, INC. 815 MONROE STREET • SUITE 101 • NEW MEXICO SPRING (505) 424-4500 FAX (505) 424-7212		ASHWIN STABLES EXISTING CONDITIONS PLAN		SCALE 1" = 40' DRAWN BY: HP	DATE APRIL 2015 CHECKED BY: JMS	SHEET P-2
ARROYO CALABASAS PLAT BK. 516 PG. 039 40.00' DRAINAGE EASEMENT 2.00' DRAINAGE EASEMENT		HOME OWNERS ASSOCIATION OPEN SPACE BK. 516 PG. 039		REVISIONS 02/20/00 09/20/00	TEXT REVISIONS 1502-5000	

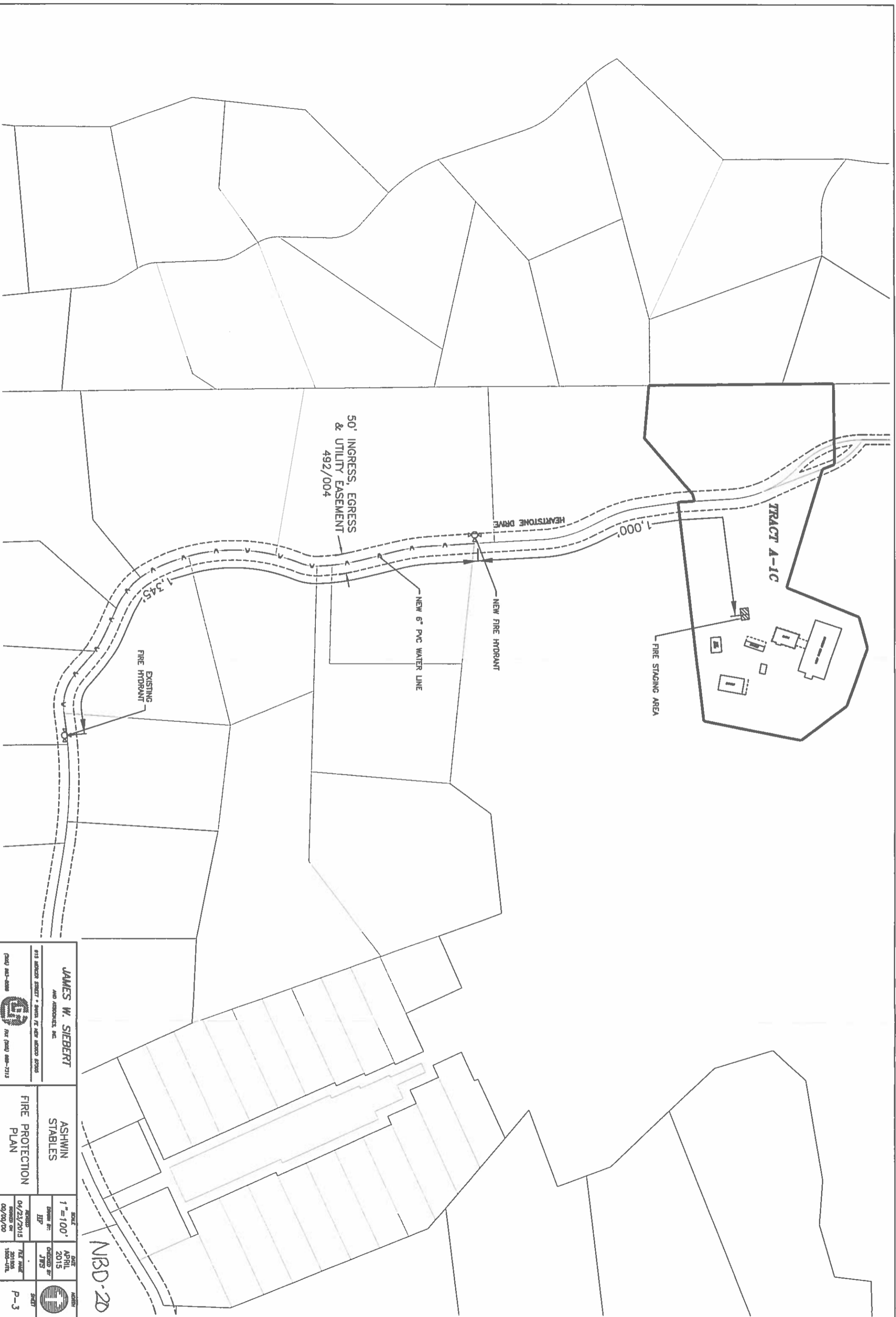

50' INGRESS, EGRESS  
& UTILITY EASEMENT  
492/004

HEARSTONE DRIVE

TRACT A-1C

FIRE STAGING AREA

NEW FIRE HYDRANT

NEW 6" PVC WATER LINE

EXISTING  
FIRE HYDRANT

NIRD-20

<b>JAMES W. SIEBERT</b> AND ASSOCIATES, INC. <small>813 BUCKING STREET • SUITE 107 NEW BRUNSWICK, NJ 08901          (732) 843-4888 FAX (732) 848-7115</small>		<b>ASHWIN STABLES</b> <b>FIRE PROTECTION PLAN</b>	
SCALE 1" = 100'	DATE APRIL 2015	DESIGNED BY JWS	PROJECT NO. P-3
DATE 04/23/2015	REVISIONS BY 02/20/20	DATE 1503-1715	SCALE AS SHOWN

SUNDANCE ESTATES SUBDIVISION  
BLOCK 1

N/F WELSH FAMILY  
LTD. PARTNERSHIP  
LOT 1  
BOOK 1482, PAGE 202

N/F WELSH FAMILY  
LTD. PARTNERSHIP  
LOT 2  
BOOK 447, PAGE 038

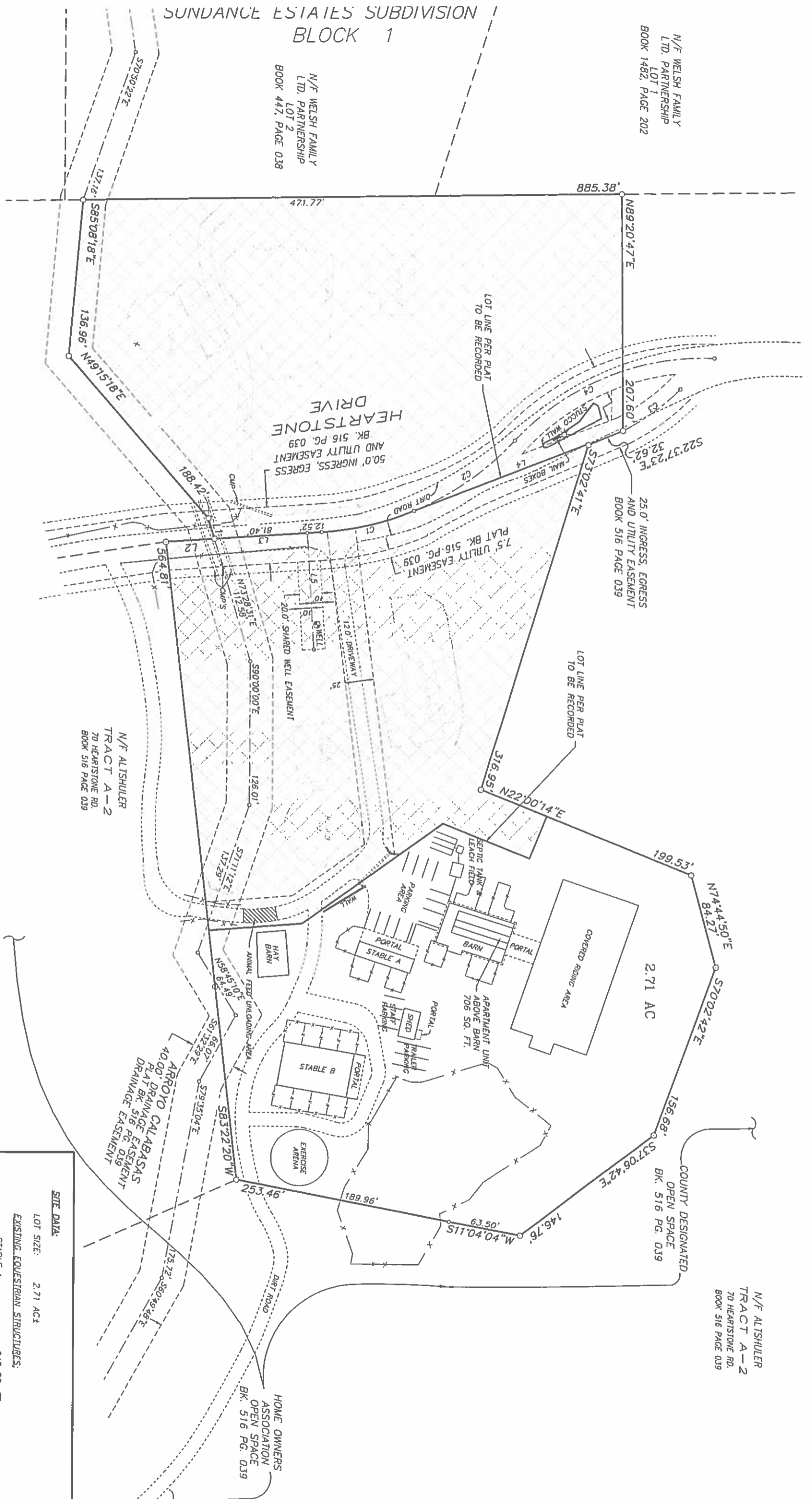

N/F ALTSHULER  
TRACT A-2  
70 HEARSTONE RD.  
BOOK 516 PAGE 039

N/F ALTSHULER  
TRACT A-2  
70 HEARSTONE RD.  
BOOK 516 PAGE 039

**JAMES W. SIEBERT**  
AND ASSOCIATES, INC.  
915 WILSON STREET • SANTA FE, NEW MEXICO 87505

**ASHWIN STABLES**

SCALE: 1" = 40'  
DRAWN BY: HP  
CHECKED BY: JMS

DATE: APRIL 2015

REVISIONS: 06/19/2015 TEL: NMBT

MASTER PLAN  
PRELIMINARY & FINAL

**SITE DATA:**  
LOT SIZE: 2.71 AC±

**EXISTING EQUESTRIAN STRUCTURES:**

STABLE A:	648 SQ. FT.
STABLE B:	1,960 SQ. FT.
BARN:	2,250 SQ. FT.
HAY BARN:	1,035 SQ. FT.
COVERED ARENA:	9,943 SQ. FT.
TOTAL AREA:	15,836 SQ. FT.

**LEGEND:**  
LOT COVERAGE: 13%

PART OF ADMINISTRATIVE LAND DIVISION APPLICATION

**NBD-21**

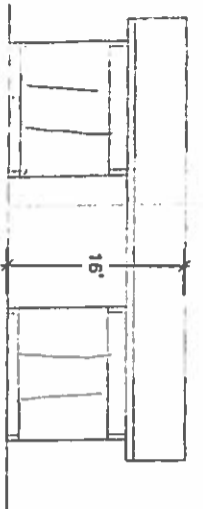

HAY BARN  
FRONT ELEVATION

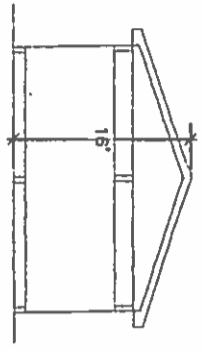

HAY BARN  
SIDE ELEVATION

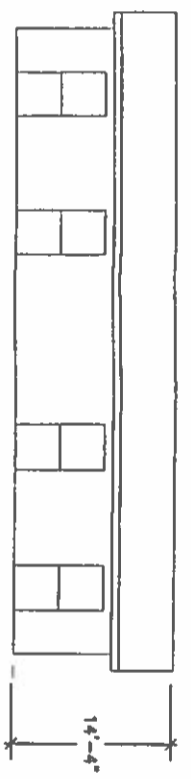

STABLE B  
FRONT ELEVATION

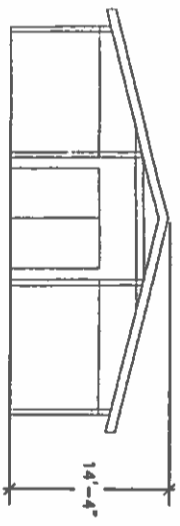

STABLE B  
SIDE ELEVATION

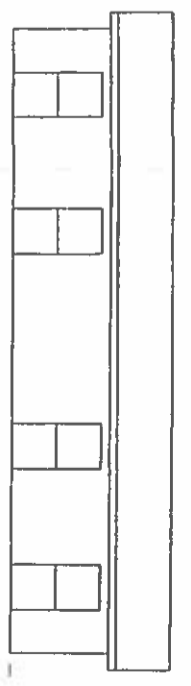

STABLE A  
FRONT ELEVATION

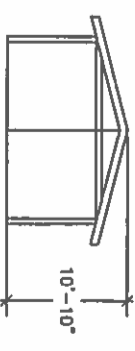

STABLE A  
SIDE ELEVATION

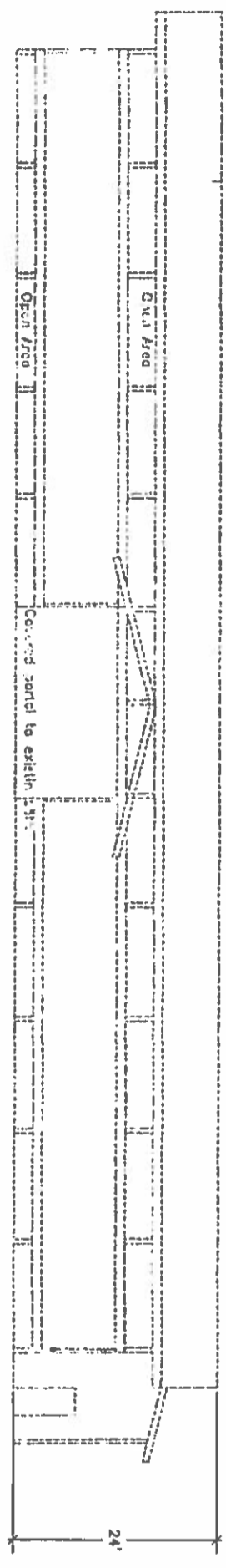

COVERED ARENA  
FRONT ELEVATION

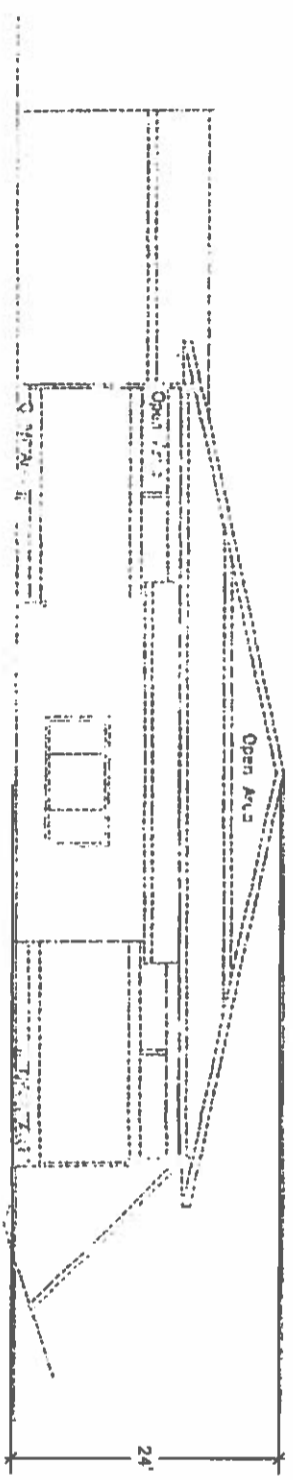

COVERED ARENA  
SIDE ELEVATION

NBD-22

<b>JAMES W. SIEBERT</b> AND ASSOCIATES, INC. 815 JEFFERSON STREET • SUITE 101 NEW JERSEY CITY (201) 546-5500 FAX (201) 546-7313		ASHWIN STABLES BUILDING ELEVATIONS		SCALE 1/8" = 1'-0" DRAWN BY JES	DATE APRIL 2015 CHECKED BY JWS	SHEET P-5
815 JEFFERSON STREET • SUITE 101 NEW JERSEY CITY (201) 546-5500 FAX (201) 546-7313		BUILDING ELEVATIONS		REVISIONS 00/00/00 00/00/00	DATE APRIL 2015	SHEET P-5

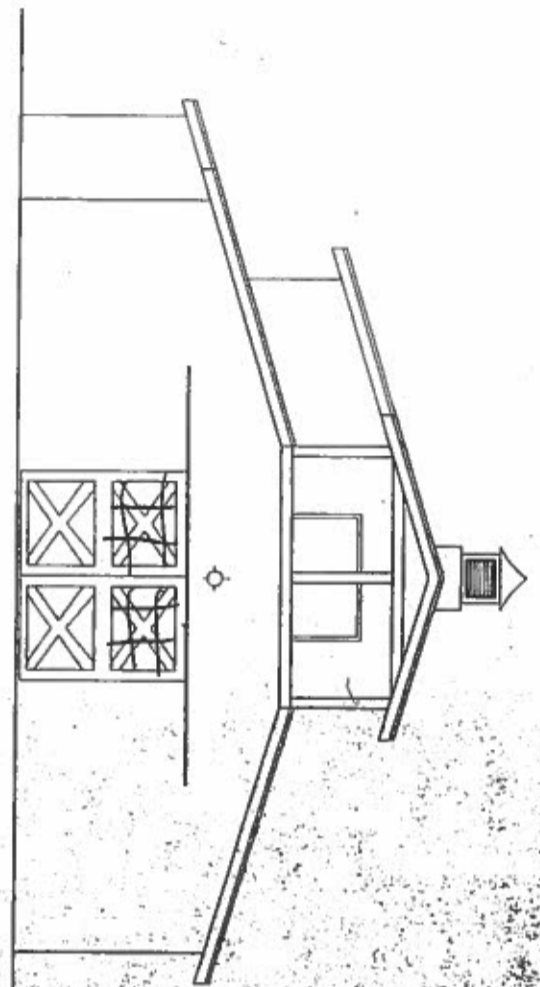

4 SOUTH ELEVATION  
SCALE 1/4"=1'-0"

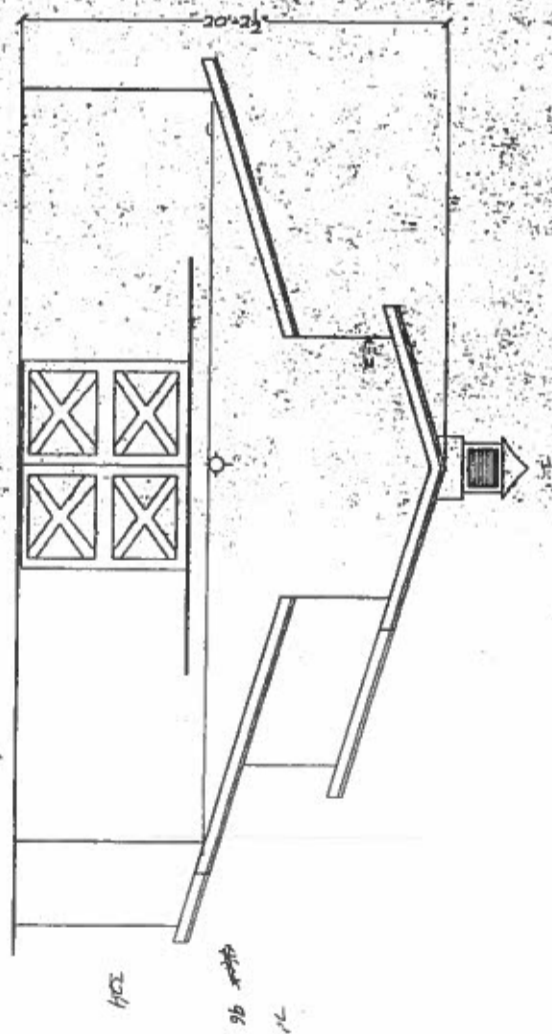

3 NORTH ELEVATION  
SCALE 1/4"=1'-0"

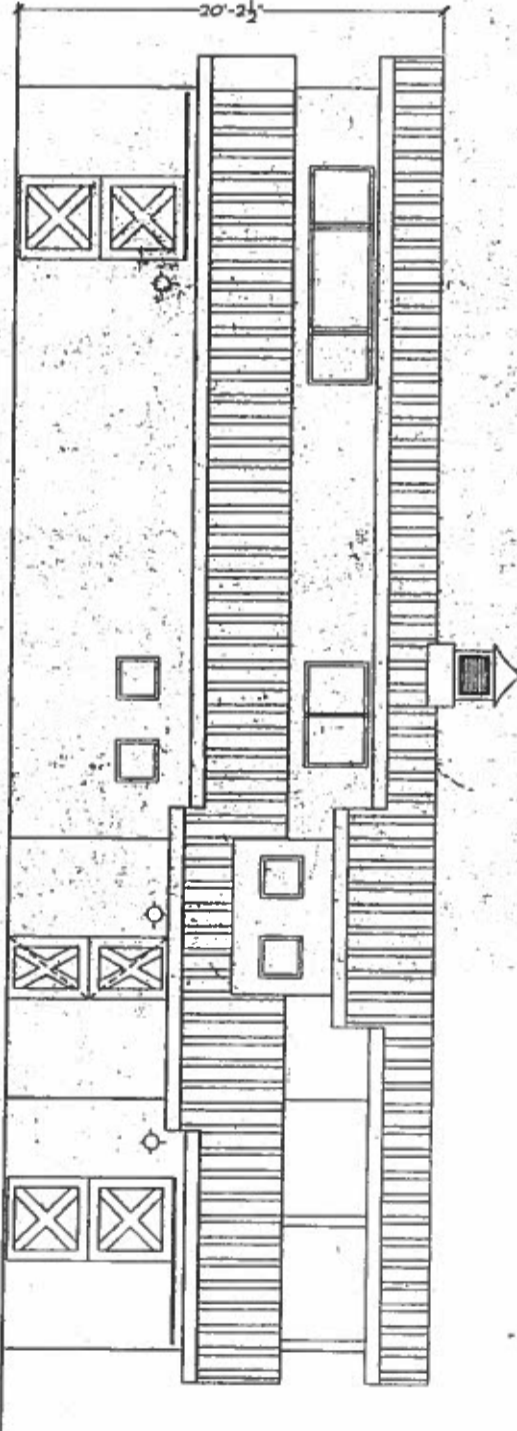

2 EAST ELEVATION  
SCALE 1/4"=1'-0"

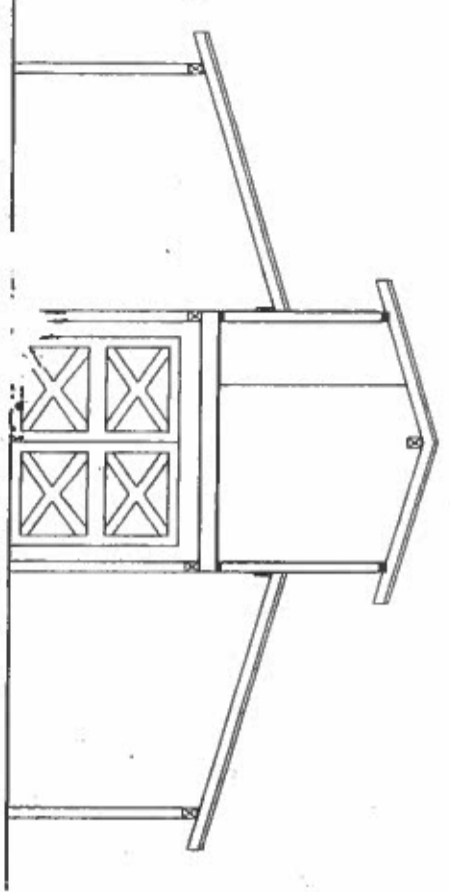

A SECTION  
SCALE

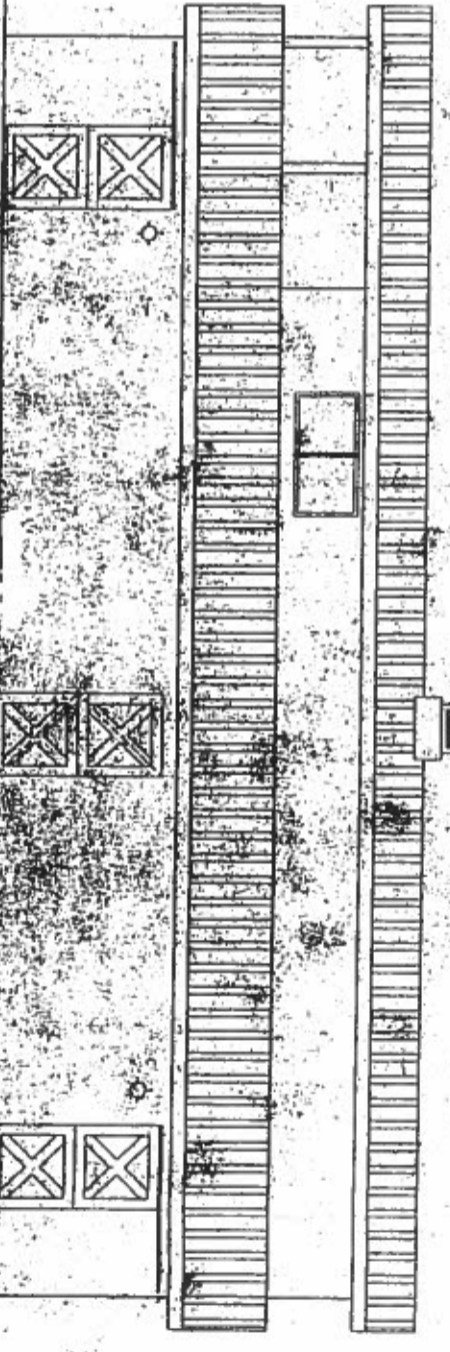

1 WEST ELEVATION  
SCALE 1/4"=1'-0"

SHEET NO. P-6	SHEET TITLE ELEVATIONS PLANS 1/4"=1'	DATE: 1/7/03 REVISION: 4-19-02	A BARN AT TANO ROAD SANTA FE, NEW MEXICO	COMMUNITY REALTY, INC. 2300 WEST ALAMEDA SANTA FE, NEW MEXICO (505) 471-1183	ARCH-TECH DRAFTING 1925 ASPEN DRIVE SUITE 801 SANTA FE, NEW MEXICO (505) 471-5727	TRACT A-1 WEST TANO BARNS
------------------	---	-----------------------------------	--	---	--	---------------------------------

N1310-23

SUNDANCE ESTATES SUBDIVISION  
BLOCK 1

N/F WELSH FAMILY  
LTD. PARTNERSHIP  
LOT 1  
BOOK 1482, PAGE 202

N/F WELSH FAMILY  
LTD. PARTNERSHIP  
LOT 2  
BOOK 447, PAGE 038

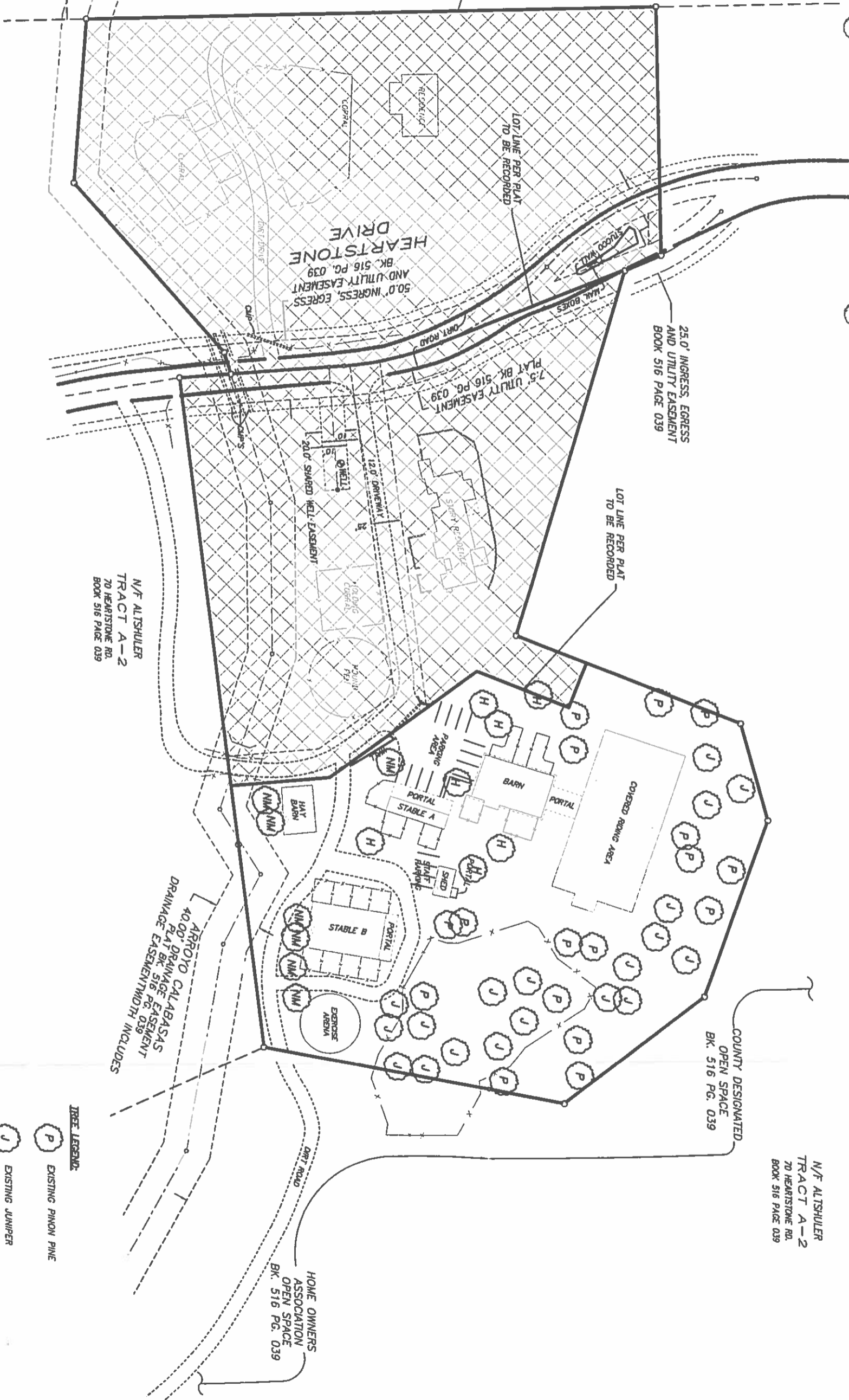

25.0' INGRESS, EGRESS  
AND UTILITY EASEMENT  
BOOK 516 PAGE 039

7.5' UTILITY EASEMENT  
PLAT BK. 516 PG. 039

50.0' INGRESS, EGRESS  
AND UTILITY EASEMENT  
BK. 516 PG. 039

N/F ALTSHULER  
TRACT A-2  
70 HEARSTONE RD.  
BOOK 516 PAGE 039

COUNTY DESIGNATED  
OPEN SPACE  
BK. 516 PG. 039

N/F ALTSHULER  
TRACT A-2  
70 HEARSTONE RD.  
BOOK 516 PAGE 039

HOME OWNERS  
ASSOCIATION  
OPEN SPACE  
BK. 516 PG. 039

ARROYO CALABASAS  
40.00' DRAINAGE EASEMENT  
PLAT BK. 516 PG. 039  
DRAINAGE EASEMENT WIDTH INCLUDES

TREE LEGEND:

- P EXISTING PINON PINE
- J EXISTING JUNIPER
- H EXISTING HONEY LOCUST
- NM EXISTING NEW MEXICO LOCUST

NBD-24

<p><b>JAMES W. SIEBERT</b> AND ASSOCIATES, INC.</p> <p>815 WILSON STREET • SUITE 177 • NEW MEXICO 87102 (505) 942-2222 FAX (505) 942-2113</p>		<p>ASHWIN STABLES</p>		<p>SCALE 1" = 40'</p> <p>DRAWN BY: JES CHECKED BY: JWS</p> <p>DATE: APRIL 2015</p>			<p>ASHTON SWIFT</p>
<p>LANDSCAPE PLAN</p>		<p>DATE: 04/02/15 ISSUED ON: 04/09/15</p>		<p>FILE NAME: 1505-030</p>			



**SANTA FE COUNTY**  
**Ordinance No. 1998-15**

1575550

---

---

**An Ordinance Amending Article III Section 8 "Other Development" of the Santa Fe County Land Development Code to Clarify the Definition of a Utility Line Extension and Clarify the Requirement for a Development Permit for Construction of Utilities**

---

---

**BE IT ORDAINED BY THE BOARD OF COUNTY COMMISSIONERS OF SANTA FE COUNTY:**

The Board of County Commissioners of Santa Fe County hereby amends for the purpose of clarifying the development permit requirements for Utilities. Specifically Article III, Section 8 "Other Development", of the Land Development Code is amended as follows:

**8.1 Uses Permitted**

Subject to the requirements of this Section, all uses not otherwise regulated by the Code are permitted anywhere in the County provided a request for zoning approval is granted per Article III, except for utility lines which may be approved administratively per subsection 8.3.7 set forth below. Such uses specifically include, but are not limited to utilities, parking facilities, and cemeteries. Notwithstanding the fact that these uses are permitted, a development permit is still required.

**8.2. Submittals, Reviews and Standards**

Uses regulated by this section 8 shall be considered large if they involve the grading and clearing of 10 or more acres, contiguously or cumulatively; and small scale if less disturbance of the land is involved. Development standards and criteria and submittal requirements are set forth in Subsection 4.4; as well as any other Section of the Code which refers to or regulates Terrain Management or Utilities.

**8.3 Utilities**

8.3.1 A development permit shall be required for, and provisions of the Code shall apply to, all development; including utilities, utility easements, utility rights-of-way, and construction of utility lines and facilities.

8.3.2 Utility Lines include the following definitions:

- A. "line" or "lines" in all cases include any appurtenant hardware, equipment, buildings, etc.;
- B. Utility service lines are lines that connect individual utility customers to the utility distribution system and facilities;
- C. Utility distribution lines are lines that interconnect the service line to a station, substation, or other parts of the distribution system or network.
- D. Utility transmission lines are lines that interconnect the distribution network(s). Typically, but not always, transmission lines, in the case of gas



NBDD-25

and electric power, make connections between, connect to, and use substations, stations, and other generating facilities.

- 8.3.3 Where any doubt exists as to a line being part of a service line, distribution line, or transmission line, such item shall be included in the larger system or facility.
- 8.3.4 Authority for installation of service lines, and their interface or point of connection to distribution lines, shall be included in the development permit for construction of buildings, subdivision plans, or other development.
- 8.3.5 A development permit is required for utility transmission and distribution lines and appurtenant facilities, including storage facilities, pipelines, transmittal towers and facility, and power and communications transmission lines. Such uses shall meet standards, as applicable, set forth in Section 8.2 above.
- 8.3.6 In addition to the above requirements, any development involving a water or sewer utility must be in conformance with an adopted Community Land Use and Utility Plan, unless system improvements are limited to that needed to serve existing development.
- 8.3.7 Development permits for purposes of Section 8, may be approved administratively subject to the policies adopted at the discretion of the Code Administrator. Such policies shall be implemented by the Code Administrator and will be effective when published and posted.
- 8.3.8 All utility lines shall be placed underground as provided in subsection 2.3.9.b.1), or upon final approval of the Board of County Commissioners, who shall consider environmental and visual impacts.
- 8.3.9 Solely in the case of telecommunications masts, microwave masts, television or radio masts, or other masts or towers for the purpose of transmitting or receiving wireless signals, such shall be regulated and zoned as "Other Development" per the requirements of Section 8.2.

History: Ordinance 1998- 15 replaced existing Section 8 to require development permits for other Development.

**PASSED, ADOPTED AND APPROVED** this 24<sup>th</sup> day of November, 1998, by the Santa Fe County Board of County Commissioners.

  
 \_\_\_\_\_  
**MARCOS TRUJILLO, CHAIRMAN**  
 Joe S. Grine, Vice Chairman

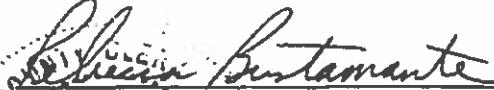
  
 \_\_\_\_\_  
**REBECCA BUSTAMANTE, COUNTY CLERK**

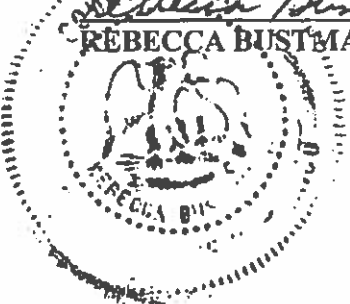

1575561

APPROVED AS TO FORM:

Robanna Vasquez for  
DENICE BROWN, COUNTY ATTORNEY

COUNTY OF SANTA FE )SS  
STATE OF NEW MEXICO 1052) 399  
I hereby certify that this instrument was filed  
for record on the 8 day of Dec. A.D.  
19 98 at 1:59 o'clock P m  
and was duly recorded in book 1575  
page 559 - 561 of the records of  
Santa Fe County.

Witness my Hand and Seal of Office  
Rebecca Bustamante  
County Clerk, Santa Fe County, N.M.

Jerome Clayton  
Deputy

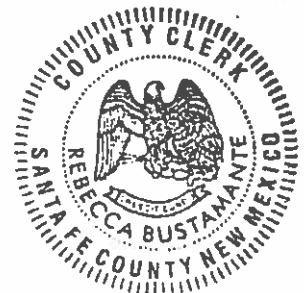

NBP-27

fulfill the proposals contained in the subdivider's disclosure statement and in determining whether or not the subdivider's provisions for a subdivision conform with County regulations.

4.8 Common Promotional Plans

The Code Administrator will review proposed applications to determine whether there is a common promotional plan to subdivide a property. If it is determined that the land division does constitute a common promotional plan, the project shall comply with the procedures provided for in this Article V.

**SECTION 5 - PROCEDURES AND SUBMITTALS**

5.1 Pre-application Procedures

Prior to the filing of an application for approval of a preliminary plat, the subdivider shall confer with the Code Administrator to become acquainted with these subdivision regulations. At this pre-application conference, the subdivider shall be advised of the following:

1. Submittals required by the Code.
2. Type and/or class of the proposed subdivision.
3. Individuals and/or agencies that will be asked to review the required submittals.
4. Required improvements.
5. Conditions under which Master Plans and Development Plans are required as described in Sections 5.2 and 7.
6. A determination will be made as to the appropriate scale and format for plans and plats and as to the appropriateness of applicable submittal requirements.



5.2 Master Plan Procedure

5.2.1 Introduction and Description

- a. Master plans are required in the following cases:
  - i. All Type I, Type II, and Type IV subdivisions with more than one development phase or tract;
  - ii. As required in Article III for developments other than subdivisions; and
  - iii. Such other projects which may elect to apply for master plan approval.
- b. A master plan is comprehensive in establishing the scope of a project, yet is less detailed than a development plan. It provides a means for the County Development Review Committee and the Board to review projects and the subdivider to obtain concept approval for proposed development without the necessity of expending large sums of money for the submittals required for a preliminary and final plat approval.
- c. The master plan submittal will consist of both plans and written reports which include the information required in 5.2.2 below. A typical submittal would include a vicinity map, a plan showing existing site data, a conceptual environmental plan with written documentation, a master plan map, a master plan report, a schematic utilities plan and the phasing schedule. Maps and reports may be combined or expanded upon at the discretion of the applicant to fit the particular development proposal as long as the relevant information is included.

5.2.2 Master Plan Submittals

- a. Vicinity Map. A vicinity map drawn at a scale of not more than 2,000 feet to one inch showing contours at twenty (20) foot intervals showing the relationship of the site to its general surroundings, and the location of all existing drainage channels, water courses and water bodies located on the parcel and within three miles of the Parcel.



NBD-28

The locations of all Federal, State, or County Roads within one thousand (1000) feet of the parcel shall be shown. In addition, location of future highways and arterials as designated on the appropriate master plan for roads in the County (see 3-19-9 N.M.S.A. 1978) shall be shown.

- b. Existing Site Data. A description of existing conditions on or adjacent to the site. Maps shall be at a scale of one (1) inch to one hundred (100) feet or other appropriate scale as determined by the Code Administrator and shall include the following:
- 1) Boundary lines: bearings and distances. The error of closure shall be of a third order survey, and no discrepancy between computed and measured distances shall exceed one (1) part in 1,280 parts;
  - 2) Easements: Location, width and purpose;
  - 3) Streets or Roads on and immediately adjacent to the tract, name and right-of-way width;
  - 4) Utilities on and immediately adjacent to the tract;
  - 5) Owners of record of unplatted land and existing subdivision plats by name and recordation, together with owners of record for affected lots shall be shown for property within one-hundred (100) feet of that tract not including public rights-of-ways.
  - 6) Title and certificates: Present tract designations according to official records in the County Clerk's Office, title under which the proposed development is to be recorded with name and address of owner, notation stating acreage, scale, true and magnetic north arrow, U.S.G.S. datum and benchmarks, if any, certification of the engineer or land surveyor licensed in accordance with the laws of the State of New Mexico who prepared the plat.
  - 7) Proof of legal access from a county or state road as required by the Code.
- c. Conceptual environmental plan shall include, when appropriate:
- 1) Graphic representation of existing topography, natural features, slopes, and floodplains.
  - 2) Soils maps and reports (SCS)
  - 3) Recreational and/or open space plan, or landscape concepts,
  - 4) Liquid waste disposal plan, and
  - 5) Water Supply plan.
- d. Master plan map(s) showing the proposed development in sketch form, including:
- 1) Proposed major vehicular and pedestrian circulation system.
  - 2) Designation and description of proposed land uses, including information about residential uses by type, area and density, and information about office, general commercial and industrial uses by area and intensity of development. Mixed uses shall not be prohibited.
  - 3) Logical and natural boundaries defining development limitations, and
  - 4) Any proposed sites for schools or other community facilities.
- e. A phasing schedule shall be included in the master plan giving a general description of each phase of the development.
- f. A schematic utilities plan showing location, locational cross sections, and approximate line sizes. It is recognized that there may be changes in the final utilities plan due to the requirements of utility companies or final engineering plans and specifications.

NBD-29

- g. Master plan report which includes the following:
- 1) A general description of the project, existing development on the parcel, location, adjacent properties, acreage, lot coverage, access, traffic impacts, terrain management, soils, landscaping, outside lighting, parking, signage, water, liquid waste, solid waste, archaeological sites and fire protection measures;
  - 2) If appropriate, market analysis and economic impact report which address: demand, projected sales and build-out; identifies a trade area; estimates retail sales and potential, and identifies the scale and extent of local competition.
  - 3) Preliminary fiscal impact estimates of net local public costs, including capital outlay and operating expenses, and revenues attributable to the proposed project.
  - 4) Preliminary environmental assessment, which identifies the possible effects of proposed development on natural resources or natural features. This may be combined with Section 5.2.2.c of this Article.
  - 5) A written preliminary traffic report prepared by a licensed traffic engineer or other qualified expert acceptable to the Code Administrator.
  - 6) Description of concepts for restrictive covenants proposed for the development if applicable, outlining the areas and extent of restriction or regulation. Detailed covenants are not required at this time.
  - 7) Schools impact report. A written report which projects the effects the proposed project will have on public schools, and which includes:
    - the proposed number, size, and price of residential units within the project;
    - a description of the project's target market; and
    - where applicable, any special educational needs of the project's school-aged residents.

The report will also identify the schools that service the area of the proposed project and their boundaries, the transportation available to those schools, and a list of any pending or approved residential developments within those schools' boundaries. Copies of the schools impacts notice shall be submitted to the school district in which the project is located and to the Code Administrator.

#### 5.2.3 Master Plan Review

The master plan shall be submitted to the Code Administrator or his authorized representative with a written application for approval. The Code Administrator will review the plan and submit analysis, written comments and a recommendation to the County Development Review Committee and the Board. Master plans shall be reviewed by the County Development Review Committee which shall make determinations regarding compliance with the County General Plan or the Extraterritorial Plan and the Code and shall forward the plan to the Board with the Committee's recommendation. The Board may adopt, amend, supplement, or reject the County Development Review Committee recommendation.

#### 5.2.4 Master Plan Approval

- a. The approved master plan shall show the area of residential use and general density measured in dwelling units per acre of land, less dedicated or conveyed rights-of-way, and the area and intensity of commercial and industrial use measured in gross square feet of building area or maximum gross floor area ratio. These shall constitute the maximum permitted number of dwelling units and maximum permitted area and intensity of commercial or industrial use.
- b. The County Development Review Committee and Board shall consider the following criteria in making determinations and recommendations for approval or amendment of master plans:
  1. Conformance to County and Extraterritorial Plan;

NBD-30

2. Suitability of the site to accommodate the proposed development;
3. Suitability of the proposed uses and intensity of development at the location;
4. Impact to schools, adjacent lands or the County in general;
5. Viability of proposed phases of the project to function as completed developments in the case that subsequent phases of the project are not approved or constructed;
6. Conformance to applicable law and County ordinances in effect at the time of consideration, including required improvements and community facilities and design and/or construction standards.

#### 5.2.5 Filing of Approved Master Plan

The approved master plan with maps which has been approved by and received signatures of the County Development Review Committee Chairman and Board Chairman shall be filed of record at the County Clerk's Office.

#### 5.2.6 Amendments and Future Phase Approvals

- a. Approval of the master plan is intended to demonstrate that the development concept is acceptable and that further approvals are likely unless the detailed development plans cannot meet the requirements of applicable law and County ordinances in effect at that time. Each phase of the development plan must be considered on its own merits.
- b. The Code Administrator may approve minor changes to the master plan. Any substantial change in land use or any increase in density or intensity of development in the approved master plan requires approval by the County Development Review Committee and the Board.
- c. Any changes approved by the Code Administrator pursuant to Section 5.2.6b of this Article shall be subject to the review and approval of County Development Review Committee and the Board at the time of development plan or plat approval.
- d. The phasing schedule may be modified by the Board at the request of the developer as economic circumstances require as long as there is no adverse impact to the overall master plan. (See Article 4, Section 4.5)

#### 5.2.7 Expiration of Master Plan

- a. Approval of a master plan shall be considered valid for a period of five years from the date of approval by the Board.
- b. Master plan approvals may be renewed and extended for additional two year periods by the Board at the request of the developer.
- c. Progress in the planning or development of the project approved in the master plan consistent with the approved phasing schedule shall constitute an automatic renewal of the master plan approval. For the purpose of this Section, "progress" means the approval of preliminary or final development plans, or preliminary or final subdivision plats for any phase of the master planned project.

History. 1980 Comp. 1980-6. Sections 4.4, 4.5, 5.1 and 5.2 were amended by County Ordinance 1987-1 to provide for the submittal of a master plan.

### 5.3 Preliminary Plat Procedure

#### 5.3.1 Introduction and Description

- 5.3.1a Preliminary plats shall be submitted for Type-I, Type-II, Type-III, except Type-III subdivisions that are subject to review under summary procedure as set forth in Subsection 5.5 of this Section, and Type-IV subdivisions.

NBD-31

**SECTION 6 - FEEs AND LEVIES****6.1 Standard Fees**

Any person desiring to subdivide land in the County shall pay the current administrative fees set by the County. A fee schedule, which may be periodically amended, is available from the Code Administrator.

**6.2 Additional Fees for Unusual Circumstances**

Where additional review by the County is required above and beyond normal review requirements due to complex, unforeseen, or unique circumstances relating to the proposed plan or plat, such as complex hydrological considerations, then the County may charge an additional review fee to defray the cost of such review. Review fees shall be only for professional services rendered to the County in the case that the County does not have qualified personnel to assist in reviewing such reports, plans and plats. When an additional fee is deemed necessary, the fee shall be arrived at between the County and the subdivider.

**SECTION 7 - DEVELOPMENT PLAN REQUIREMENTS****7.1 Preliminary Development Plans****7.1.1 Pre-application conference**

- a. Prior to the application for approval of a preliminary development plan for any phase or for an entire project, the subdivider may confer with the Code Administrator regarding the plan submittal and requirements of the Code according to Section 5.1 of this Article.
- b. At this time a determination will be made as to the appropriate scale and format for plans and plats and as to the appropriateness of applicable submittal requirements.

**7.1.2 Information to be submitted**

- a. Evidence of legal lot of record;
- b. Contour intervals of two feet or such other appropriate scale as determined by the Code Administrator;
- c. Arrangements, location and size of buildings, where applicable;
- d. Off-street parking and loading or dumping facilities, where applicable;
- e. Internal vehicular and pedestrian circulation, and ingress and egress;
- f. A drainage, grading, and erosion control plan including existing and proposed contours for roads and utilities; a preliminary/conceptual grading plan around buildings, when applicable;
- g. A landscaping plan providing a schedule specifying conceptual methods, to include type, size, and location of vegetative and non-vegetative landscape material, and a preliminary description of the irrigation system to be used;
- h. Walls, fences and earth berms; their approximate locations and identifying types of fences and walls, if applicable;
- i. Size, location, orientation, lighting and type of signage, where applicable;
- j. Conceptual plan for outdoor lighting, including type, size, location of fixtures, if applicable;
- k. Easements, rights-of-way and street design:
  - l. Access to telephone, gas, and electric utility service;
  - m. Utility plan for water and sanitary sewer;
  - n. Residential densities/gross acres;





- o. Intensity of non-residential development, including lot coverages, gross floor area ratios or gross square feet of building area;
- p. A vicinity map showing the boundaries of the project, owners of record within one hundred feet of the tract including public rights-of-way and existing conditions and development, including adjacent streets and utilities, for at least two hundred feet from the project boundaries;
- q. If appropriate, the phases and approximate dates of development of the phases;
- r. The plan shall be drawn at a scale of one hundred feet (100') to the inch or such other appropriate scale as determined by the Code Administrator;
- s. Proposed community facilities and/or sites and recreational areas, if any, and proposed ownership of such;
- t. A schedule of on-site and off-site public improvements with the time of construction related to the phasing schedule;
- u. Information as required by state agencies;
- v. The preliminary subdivision plat may be submitted concurrently with the preliminary development plan, but is not required. Submittal of a schematic or sketch subdivision plat showing proposed lot layout, approximate dimensions and lot areas together with topography and natural features; and
- w. A written traffic report prepared by a licensed traffic engineer or other qualified expert as determined by the Code Administrator.
- x. Schools Impact Report. A written report which projects the effects the proposed project will have on public schools, and which includes: the proposed number, size, and price of residential units within the project; a description of the project's target market; and where applicable, any special educational needs of the project's school-aged residents. The report will also identify the schools that service the area of the proposed project and their boundaries, the transportation available to those schools, and a list of any pending or approved residential developments within those schools' boundaries. Copies of the schools impacts notice shall be submitted to the school district in which the project is located and to the Code Administrator.
- y. Water Supply Plan - Water System. As required by Article VII, Section 6 of the Code and Table 5.1. of Section 9.3 of this Article V.
- z. Solid Waste Disposal Plan. As required by Article VII, Section 7 of the Code.
- aa. Liquid Waste (Disposal) Plan. As required by Article VII, Section 2 of the Code.
- bb. Timing and Phasing of Development. Projections for 5 to 10 years.
- cc. Copies of deed restrictions and protective covenants must be submitted.

#### 7.1.3 Review

- a. A preliminary development plan may be only a phase or portion of the area covered by an approved master plan, so long as the preliminary development plan substantially conforms to the approved master plan.
- b. A preliminary development plan shall be submitted prior to or concurrent with submission of a preliminary plat.
- c. The application for preliminary development plan approval shall be presented to the County Development Review Committee for review with a staff report. The staff report shall include a description of the proposed project, an evaluation of pertinent planning issues, and a statement on the compliance of the project with the County General Plan and Code. The report may include recommended conditions of approval. The report shall include all comments from appropriate State or Federal agencies, the County Fire Marshal, the County Hydrologist, and other appropriate County personnel. Particular attention shall be given in the staff report to public

NBD-33

1306065

~~agency comments which relate to potential limitations of lot size, intensity, or character of development.~~

~~7.1.4 Criteria for development plan phase approval~~

- ~~a. Conformance to the approved master plan;~~
- ~~b. The plan must meet the criteria of Section 5.2.4 of this Article~~

7.2 Final Development Plan

7.2.1 Submittals

A final development plan conforming to the approved preliminary plan and approved preliminary plat, if required, and containing the same required information shall be submitted. In addition, the final development plan shall show, when applicable, and with appropriate dimensions, the locations and size of buildings, heated floor area of buildings, and minimum building setbacks from lot lines or adjoining streets. Documents to be submitted at this time are: proof of ownership including necessary title documents, articles of incorporation and by-laws of owners' association; required disclosure statements; final engineering plans and time schedule for grading, drainage, and all improvements including roads, water system, sewers, solid waste, utilities; engineering estimates for bonding requirements; development agreements; and final subdivision plats, if required.

7.2.2 Review

The final development plan shall be submitted to the County Development Review Committee accompanied by a staff report. The County Development Review Committee shall review the plan and make a determination as to its compliance with the County General Plan and Code. The County Development Review Committee may recommend changes or additions to the plan as conditions of its approval. The final development plan as approved by the County Development Review Committee shall be filed with the County Clerk. The approved final development plan becomes the basis of development permits and for acceptance of public dedications. Any changes in the plan must be approved by the County Development Review Committee.

History. 1980 Comp. 1980-6. Section 7 of Article V was amended by County Ordinance 1987-1 adding language relating to master plans.

**SECTION 8 - SUBDIVISION DESIGN STANDARDS**

~~These standards shall be binding upon the subdivider unless modifications are justified by sound engineering principles. Such modifications from these standards may be approved by the Board after a review by the County Development Review Committee upon presentation of documented justification by a licensed professional engineer.~~

8.1 General Policy on Roads

8.1.1 General

~~The arrangement, character, extent, width, grade and location of all roads shall be considered in relation to convenience and safety, and to the proposed uses of land to be served by such roads. Prior to grading or roadway cuts, all applicable permits shall be granted by the Code Administrator.~~



NBD-34

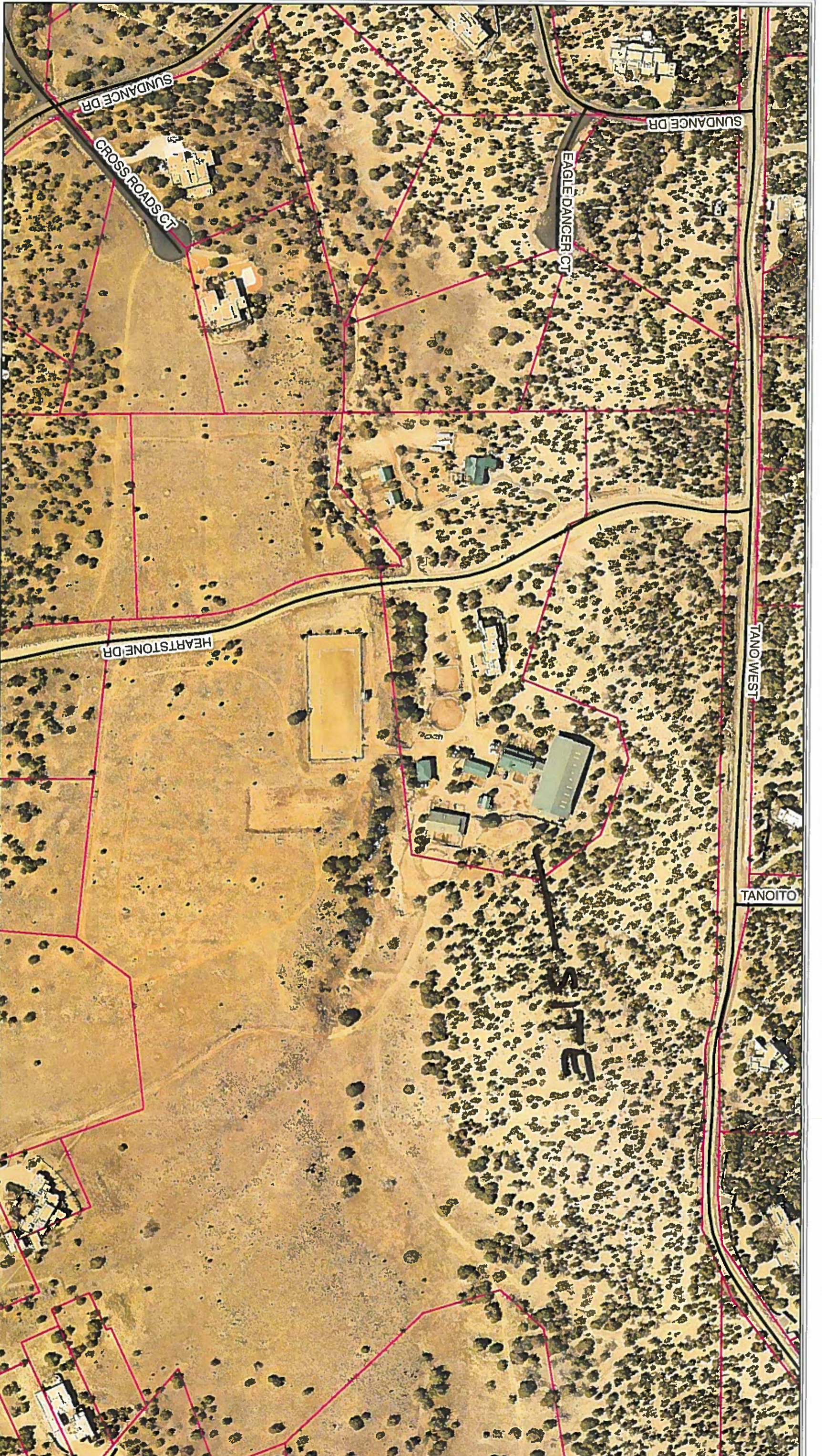

**Legend**

ROADS

PARCELS



1:2,137  
1 inch represents 178,075458 feet



2015 Imagery  
2 FOOT CONTOURS

This information is for reference only.  
Santa Fe County assumes no liability for  
errors associated with the use of these data.  
User are solely responsible for  
confirming data accuracy.

NBD-35



June 22, 2015



Susana Martinez  
Governor

STATE OF NEW MEXICO  
**DEPARTMENT OF CULTURAL AFFAIRS  
HISTORIC PRESERVATION DIVISION**

BATAAN MEMORIAL BUILDING  
407 GALISTEO STREET, SUITE 236  
SANTA FE, NEW MEXICO 87501  
PHONE (505) 827-6320 FAX (505) 827-6338

May 20, 2015

Jose E. Larrañaga  
Development Review Team Leader  
County of Santa Fe  
102 Grant Avenue  
P.O. Box 276  
Santa Fe, NM 87504-0276

RE: CDRC Case # Z/PDP/FDP Ashwin Stables

Dear Mr. Larrañaga:

I have completed my review of the above referenced master plan/preliminary and final development plan, received at the Historic Preservation Division (HPD) on April 20, 2015. According to our records, and the archaeological survey report prepared in 2002 for the property, there are no historic properties listed on the State Register of Cultural Properties or the National Register of Historic Place within the project parcel. One archaeological site appears to be within or very near the project area; however, this site was determined to be ineligible for listing in the State or National Registers. Because this site is not significant, the proposed project will have No Effect on Historic Properties.

Please do not hesitate to contact me if you have any questions. I can be reached by telephone at (505) 827-4064 or by email at [michelle.ensey@state.nm.us](mailto:michelle.ensey@state.nm.us).

Sincerely,

Michelle M. Ensey  
Archaeologist

Log: 101273



NBD-36



June 04, 2015

Jose E. Larranaga,  
Development Review Team Leader  
Santa Fe County  
102 Grant Avenue  
Santa Fe, NM 87504-0276

RE: CDRC CASE#Z/PDP/FDP Ashwin Stables Final Development Plan

Dear Mr. Larranaga:

The New Mexico Department of Transportation (NMDOT) District 5 Traffic Section has reviewed the Master Plan/Preliminary & Final Development Plan for Ashwin Stables final development. The proposed development is within the County of Santa Fe, New Mexico and consists of several types of Land uses off our roadway system.

We are in agreement with your findings and recommendations that this development will not impact our State transportation system. We therefore approve the study.

Please feel free to contact me at (505)995 7802 if you have any questions.

Sincerely

  
M S JAWAD, P.E.  
District 5 Asst. Traffic Engineer

Cc: Habib Abi-Khalil, Assistant District Engineer – Engineering Support  
Javier Martinez, District 5 Traffic Engineer  
Jeremy Lujan, Property Management Unit

**Susana Martinez**  
Governor

**Tom Church**  
Interim Cabinet Secretary

**Commissioners**

**Pete Rahn**  
Chairman  
District 3

**Ronald Schmeits**  
Commissioner  
District 4

**Dr. Kenneth White**  
Secretary  
District 1

**Robert R. Wallach**  
Commissioner  
District 2

**Butch Mathews**  
Commissioner  
District 5

**Jackson Gibson**  
Commissioner  
District 6



STATE OF NEW MEXICO  
**OFFICE OF THE STATE ENGINEER**  
CONCHA ORTIZ Y PINO BUILDING, 130 SOUTH CAPITOL, SANTA FE, NM 87501  
TELEPHONE: (505) 827-6091 FAX: (505) 827-3806

**TOM BLAINE, P.E.**  
**STATE ENGINEER**

May 15, 2015

Mailing Address:  
P.O. Box 25102  
Santa Fe, NM 87504-5102

Jose E. Larrañaga  
Development Review Team Leader  
Santa Fe County  
P.O. Box 276  
Santa Fe, NM 87504-0276

**CERTIFIED MAIL**  
**RETURN RECEIPT**  
**REQUESTED**

**Reference: Ashwin Stables Master Plan and Preliminary/Final Development Plan**

Dear Mr. Larrañaga:

On April 20, 2015, the Office of the State Engineer (OSE) received a request to provide comments for the Ashwin Stables Master Plan and Preliminary/Final Development Plan submittal.

The proposal makes a request to change the proposed use from the existing Equestrian Use to Other Development. The development, which was previously built, included stalls for 16 horses, a small residence for the person taking care of the horses, an indoor riding arena, an outdoor riding corral and a hay barn. It is located south of Tano West Road, which is also designated as a County Road 84A, within Section 4, Township 17 North, Range 9 East, NMPM. The proposed water will be supplied by an existing well (RG 76968).

This proposal was reviewed pursuant to the Santa Fe County Land Development Code (Code) and the New Mexico Subdivision Act.

When a development/subdivision proposal is received by the OSE, the developer's water demand analysis is reviewed (pursuant to the Code) to determine if it is technically correct and reasonable.

The proposal includes a water budget which estimates water use for the stables and a one person residence as 0.23 acre-feet per annum. The existing well (RG 76968) is a shared well for the proposed development and two additional lots located within the 7.75 acres parcel. According to the proposal, well RG 76968 is limited to 0.75 acre-feet per annum for all three lots.

There currently is not a meter on this well, but the applicant understands that a meter will have to be installed and meter readings submitted to the OSE on a quarterly basis.

NB0-38

Section 47-6-11.F (1) of the New Mexico Subdivision Act requires that the developer provide documents demonstrating that water sufficient in quantity to fulfill the maximum annual water requirements of the subdivision is available. Therefore, the OSE reviews the water rights and the physical water availability.

Article VII, Section 6.1 of the Code allows the Santa Fe County Land Use staff to refer development plans to state agencies for review "*if, in the opinion of the County Hydrologist and the Code Administrator, such referrals will provide information necessary to the determination of whether or not a proposed development is in conformance with provisions of this Code*". The OSE recognizes the proactive actions on behalf of the County to solicit the technical opinion of the OSE on this development plan. However, because the proposed development is not formally covered under the New Mexico Subdivision Act, the OSE declines to provide an opinion at this time. We appreciate the opportunity to review the Ashwin Stables Master Plan and Preliminary/Final Development Plan.

If you have any questions, please call Emily Geery at 505-827-6664.

Sincerely,



Molly Magnuson, P.E.  
Water Use & Conservation Acting Bureau Chief

cc: OSE Water Rights Division, Santa Fe Office

NBP-39



SUSANA MARTINEZ  
Governor  
JOHN A. SANCHEZ  
Lieutenant Governor

NEW MEXICO  
ENVIRONMENT DEPARTMENT

2540 Camino Edward Ortiz  
Santa Fe, NM 87507  
Phone (505) 827-1840 Fax (505) 827-1839  
www.nmenv.state.nm.us



RYAN FLYNN  
Cabinet Secretary  
BUTCH TONGATE  
Deputy Secretary

May 20, 2015

Mr. Jose Larrañaga  
Development Review Team Leader  
Santa Fe County  
102 Grant Avenue, P.O. Box 276  
Santa Fe, NM 87504-0276

**RE: CDRC CASE # Z/PDP/FDP  
Ashwin Stables**

Hello Mr. Larrañaga:

I have reviewed the Master Plan/Preliminary & Final Development Plan Submittal you sent for Ashwin Stables.

There is an existing, on-site liquid waste disposal system on the property (SF080264) that serves the barn, the residence located above the barn, and clients of the horse trainer. Based on the proposed development, this system appears to be adequate for this use. Therefore, I have no comments at this time.

Please contact me with any questions or if you need additional information.

Sincerely,

Bill Brown  
Liquid Waste Specialist, District II  
New Mexico Environment Department  
2540 Camino Edward Ortiz  
Santa Fe, NM 87507  
505-827-1840 office

NBD-40



Henry P. Roybal  
Commissioner, District 1

Virginia Vigil  
Commissioner, District 2

Robert A. Anaya  
Commissioner, District 3



Kathy Holian  
Commissioner, District 4

Elizabeth Stefanics  
Commissioner, District 5

Katherine Miller  
County Manager

**MEMORANDUM**

**TO:** Jose E. Larranaga, Development Review Team Leader  
**FROM:** Jerry Schoeppner, SFC Utilities  
**THROUGH:** Claudia I. Borchert, Utilities Director  
**SUBJECT:** Master Plan/Preliminary & Final Development Plan, Ashwin Stables  
**DATE:** 6/17/2015

---

This memorandum provides review of the water availability portion of the Master Plan/Preliminary & Final Development Plan for Ashwin Stables to allow an equestrian facility on 2.71 acres. The proposed Ashwin Stable lot falls under non-residential development, in which the project as a whole uses up to 0.25 acre-foot of water annually.

The applicant's submittal indicates that the property totals 7.746 acres, 2.711 acres of which is proposed to be used as an equestrian facility. The applicant proposes to provide water to the equestrian facility (Tract A1C-1C), which includes a single residential unit, an adjoining residential unit (Tract A1C-1B) and a third lot (A1C-1A) via an existing domestic well permitted by the Office of the State Engineer (OSE). The well is identified by OSE as RG -76968 and the property lies within the basin hydrologic zone.

Santa Fe County (County) previously approved a lot split administratively and limited water use to 0.75 acre-foot per year for the entire 7.746 acre property. Therefore, each lot is limited to 0.25 acre-foot. **Each lot owner will be required to read their individual meter monthly and submit those readings to the County annually to ensure compliance with this requirement.**

The applicant provided a water budget and states that a meter is not installed on the well and that one will be installed to measure usage. The OSE records indicate a meter is installed and water use has been recorded (2015 use was reported at 0.585 acre-feet). Please have the applicant clarify and provide any other meter readings if available.

NBD-41

**Henry P. Roybal**  
Commissioner, District 1

**Miguel M. Chavez**  
Commissioner, District 2

**Robert A. Anaya**  
Commissioner, District 3



**Kathy Holian**  
Commissioner, District 4

**Liz Stefanics**  
Commissioner, District 5

**Katherine Miller**  
County Manager

**Date:** May 12, 2015

**To:** Jose Larranaga, Land Use Department

**From:** Paul Kavanaugh, Engineering Associate Public Works *R*  
Johnny P. Baca, Traffic Manager Public Works *JB*

**Re:** CDRC CASE #Z/PDP/FDP Ashwin Stables Zoning, Preliminary & Final Development Plan.

---

The referenced project has been reviewed for compliance of the Land Development Code, and shall conform to roads and driveway requirements of **Article V (Subdivision Design Standards) and Section 8.1 (General Policy on Roads)**. The referenced project is located within Santa Fe County Zoning Jurisdiction, southwest of County Road 72 (Tano Road) /County Road 85A (Tano Road West) intersection and east of Heartstone Drive. The applicant is requesting a Zoning approval, Preliminary and Final Development Plan approval for an existing equestrian facility on approximately a 2.711 acre tract.

**Access:**

The property that is subject to approval was previously approved as an administrative lot split creating four lots to establish the boundary of the Heartstone Subdivision. The existing equestrian structures on the property were built for use by the residents of Heartstone Subdivision. These facilities were permitted and constructed in the time period from 2001-2005.

The applicant is proposing to access the proposed development from Heartstone Drive a 24 foot, two lane road with an asphalt surface. This road was constructed as part of the Heartstone Subdivision. Heartstone Drive is privately maintained by the Home Owners Association.

The Institute of Transportation Engineers (ITE) was used for the trip generation data for traffic impact analysis. The *Institute of Transportation Engineers Trip Generation 8<sup>th</sup> Edition*; does not have a specific designation for Equestrian facility, however, ITE 412 County Park (2.71 Acres) was used, which is consistent with what Santa Fe County has used for other equestrian facilities and will generate approximately 33 Total Driveway Trips for a 24 hour Two Way Volume. Therefore, no Traffic Impact Study is required.

**Conclusion:**

Public Works has reviewed the applicant's submittal, and feels that they can support the above mentioned project for Zoning approval, Preliminary and Final Development approval.

Henry P. Roybal  
Commissioner, District 1

Miguel Chavez  
Commissioner, District 2

Robert A. Anaya  
Commissioner, District 3



Kathy Holian  
Commissioner, District 4

Liz Stefanics  
Commissioner, District 5

Katherine Miller  
County Manager

## Santa Fe County Fire Department Fire Prevention Division

### Official Submittal Review

Date	5/20/15		
Project Name	Ashwin Stables		
Project Location	10 Heartstone Drive		
Description	Equestrian Facility	Case Manager	J. Larranaga
Applicant Name	Don Altshuler	County Case #	15-5130
Applicant Address	22 Plano Arbolito Santa Fe, NM 87506	Fire District	Agua Fria
Applicant Phone	505-983-5588 (agent)		
Review Type	Commercial <input type="checkbox"/>	Residential <input type="checkbox"/>	Sprinklers <input type="checkbox"/>
	Master Plan <input checked="" type="checkbox"/>	Preliminary <input checked="" type="checkbox"/>	Final <input checked="" type="checkbox"/>
	Wildland <input type="checkbox"/>	Variance <input type="checkbox"/>	Hydrant Acceptance <input type="checkbox"/>
		Inspection <input type="checkbox"/>	Lot Split <input type="checkbox"/>
Project Status	Approved <input type="checkbox"/>	Approved with Conditions <input checked="" type="checkbox"/>	Denial <input type="checkbox"/>

The Fire Prevention Division/Code Enforcement Bureau of the Santa Fe County Fire Department has reviewed the above submittal and requires compliance with applicable Santa Fe County fire and life safety codes, ordinances and resolutions as indicated (*Note underlined items*) :

#### Fire Department Access

*Shall comply with Article 9 - Fire Department Access and Water Supply of the 1997 Uniform Fire Code inclusive to all sub-sections and current standards, practice and rulings of the Santa Fe County Fire Marshal*

#### ▪ Roadways/Driveways

*Shall comply with Article 9, Section 902 - Fire Department Access of the 1997 Uniform Fire Code inclusive to all sub-sections and current standards, practice and rulings of the Santa Fe County Fire Marshal.*

Roads shall meet the minimum County standards for fire apparatus access roads of a minimum 12' wide all-weather driving surface and an unobstructed vertical clearance of 13' 6" within this type of proposed development. If a gate is proposed it shall be minimum 14' wide.

The proposed fire department staging area has been reviewed and approved.

- **Street Signs/Rural Address**

Section 901.4.4 Premises Identification (1997 UFC) *Approved numbers or addresses shall be provided for all new and existing buildings in such a position as to be plainly visible and legible from the street or road fronting the property.*

Section 901.4.5 Street or Road Signs. (1997 UFC) *When required by the Chief, streets and roads shall be identified with approved signs.*

Properly assigned legible rural addresses shall be posted and maintained at the entrance(s) to each individual lot or building site within 72 hours of the commencement of the development process for each building.

- **Slope/Road Grade**

Section 902.2.2.6 Grade (1997 UFC) *The gradient for a fire apparatus access road shall not exceed the maximum approved.*

Driveway/fire access shall not exceed 11% slope and shall have a minimum 28' inside radius on curves.

- **Restricted Access/Gates/Security Systems**

Section 902.4 Key Boxes. (1997 UFC) *When access to or within a structure or an area is unduly difficult because of secured openings or where immediate access is necessary for life-saving or firefighting purposes, the chief is authorized to require a key box to be installed in an accessible location. The key box shall be of an approved type and shall contain keys to gain necessary access as required by the chief.*

To prevent the possibility of emergency responders being locked out, all access gates should be operable by means of a key or key switch, which is keyed to the Santa Fe County Emergency Access System (Knox Rapid Entry System). Details and information are available through the Fire Prevention office.

## **Fire Protection Systems**

- **Water Storage/Delivery Systems**

*Shall comply with Article 9, Section 903 - Water Supplies and Fire Hydrants of the 1997 Uniform Fire Code, inclusive to all sub-sections and current standards, practice and rulings of the Santa Fe County Fire Marshal.*

*Section 903.2 Required Water Supply for Fire Protection. An approved water supply capable of supplying the required fire flow for fire protection shall be provided to all premises upon which facilities, buildings or portions of buildings are hereafter constructed or moved into or within the jurisdiction. When any portion of the facility or building protect is in excess of 150 feet from a water supply on a public street, as measured by an approved route around the exterior of the facility or building, on-site fire hydrants and mains capable of supplying the required fire flow shall be provided when required by the chief.*

*Section 903.3 Type of Water Supply (1997 UFC) Water supply is allowed to consist of reservoirs, pressure tanks, elevated tanks, water mains or other fixed systems capable of providing the required fire flow. In setting the requirements for fire flow, the chief may be guided by Appendix III-A.*

The subdivision where this project is located has an existing, approved water storage system.

- **Hydrants**

*Shall comply with Article 9, Section 903 - Water Supplies and Fire Hydrants of the 1997 Uniform Fire Code, inclusive to all sub-sections and current standards, practice and rulings of the Santa Fe County Fire Marshal.*

*Section 903.4.2 Required Installations. (1997 UFC) The location, number and type of the fire hydrants connected to a water supply capable of delivering the required fire flow shall be provided on the public street or on the site of the premises or both to be protected as required and approved.*

Fire hydrants subject to possible vehicular damage shall be adequately protected with guard posts in accordance with Section 8001.11.3 of the 1997 UFC.

As discussed, a new hydrant shall be located within 1,000 feet of the proposed staging area.

Fire hydrant locations shall be no further than 10 feet from the edge of the approved access roadways with the steamer connections facing towards the driving surface. Final placement of the fire hydrants shall be coordinated and approved by the Santa Fe County Fire Department prior to installation.

Supply lines shall be capable of delivering a minimum of 500 gpm with a 20-psi residual pressure to the attached hydrants. The design of the system shall be accordingly sized and constructed to accommodate for the associated demands placed on such a system through drafting procedures by fire apparatus while producing fire flows. The system shall accommodate the operation of two pumping apparatus simultaneously from separate locations on the system. Final design shall be approved by the Fire Marshal.

All hydrants shall have NST ports, as per the County thread boundary agreement.

No building permits shall be granted until such time as the fire hydrants have been tested and approved by the Santa Fe County Fire Marshal.

All hydrants shall comply with Santa Fe County Resolution 2000-55, Hydrant color-coding, marking and testing. Note: Please have the installing contractor contact this office prior to the installation of the fire hydrant, so that we may assist you in the final location placement and avoid delays in your projects' final approval.

## **Life Safety**

Fire Protection requirements listed for this development have taken into consideration the hazard factors of potential occupancies as presented in the developer's proposed use list. Each and every individual structure of a private occupancy designation will be reviewed and must meet compliance with the Santa Fe County Fire Code (1997 Uniform Fire Code and applicable NFPA standards) and the 1997 NFPA 101, Life Safety Code, which have been adopted by the State of New Mexico and/or the County of Santa Fe.

## **Urban-Wildland Interface**

*SFC Ordinance 2001-11, Urban Wildland Interface Code*

This development location is rated within a "Very High Wildland-Urban Hazard Area" and shall comply with all applicable regulations within the SFC Ordinance 2001-11 / EZA 2001-04 as applicable for the Urban Wildland Interface Code governing such areas.

### **▪ Building Materials**

Buildings and structures located within urban wildland interface areas, not including accessory structures, shall be constructed in accordance with the Fire Code, the Building Code and the Urban Wildland Interface Code.

### **▪ Location/Addressing/Access**

Per SFC 2001-11/EZA 2001-04, addressing shall comply with Santa Fe County Rural addressing requirements.

Per SFC 2001-11 / EZA 2001-04 Chapter 4, Section 3.2 Roads and Driveways; *Access roads, driveways, driveway turnarounds and driveway turnouts shall be in accordance with provisions of the Fire Code and the Land Development Code.* Roads shall meet the minimum County standards for fire apparatus access roads within this type of proposed development.

### **▪ Vegetation Management**

It is recommended that the development also have a vegetation management plan to establish fire-safe areas and to minimize the threat and occurrence of fire in the urban wildland interface areas. Assistance in details and information are available through the Fire Prevention Division

## General Requirements/Comments

### ▪ Inspections/Acceptance Tests

Shall comply with Article 1, Section 103.3.2 - New Construction and Alterations of the 1997 Uniform Fire Code, inclusive to all sub-sections and current standards, practice and rulings of the Santa Fe County Fire Marshal.

The developer shall call for and submit to a final inspection by this office prior to the approval of the Certificate of Occupancy to ensure compliance to the requirements of the Santa Fe County Fire Code (1997 UFC and applicable NFPA standards) and the 1997 NFPA 101, Life Safety Code.

Prior to acceptance and upon completion of the permitted work, the Contractor/Owner shall call for and submit to a final inspection by this office for confirmation of compliance with the above requirements and applicable Codes.

### ▪ Permits

As required

## Final Status

Recommendation for Final Development Plan approval with the above conditions applied.

*Victoria DeVargas, Inspector*

  
Code Enforcement Official

  
Date

Through: David Sperling, Chief  
Buster Patty, Battalion Chief Fire Marshal 

File: WestReg/DevRev/AguaFria/AshwinStables.doc

Cy: J. Lamanaga, Land Use  
Battalion Chiefs  
Regional Lieutenants  
District Chief  
Applicant  
File

**Daniel "Danny" Mayfield**  
*Commissioner, District 1*

**Miguel M. Chavez**  
*Commissioner, District 2*

**Robert A. Anaya**  
*Commissioner, District 3*

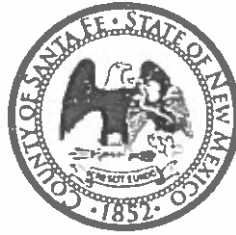

**Kathy Holian**  
*Commissioner, District 4*

**Liz Stefanics**  
*Commissioner, District 5*

**Katherine Miller**  
*County Manager*

## MEMORANDUM

DATE: May 14, 2015  
TO: Jose Larranaga, Development Review Team Leader  
FROM: Caleb Mente, Development Review Specialist  
FILE REF.: CDRC CASE #MPZ/PDP/DP/15-5130 Ashwin Stables

---

### REVIEW SUMMARY

The Referenced Project has been reviewed for compliance with the Santa Fe County Land Development Code. The request is for an Equestrian Facility Master Plan Zoning/ Preliminary and Final Development Plan on 7.746 acres. The subject property is located at 10 Heartstone Drive, south of Tano West.

### LEGAL LOT OF RECORD

The applicant has submitted a warranty deed (recorded as document # 1420118) and a survey plat (recorded in book 697 page 029) as per Article III section 2.4.B1 **Submittals**. Staff has determined that the documentation provided does prove legal lot for the subject property.

### SUMMARY REVIEW SUBDIVISION:

The applicant has provided a survey that proposes a summary review subdivision of one (1) lot into three (3) lots. Staff has determined that the proposed summary review subdivision does meet density requirements of Article III section 10 and must comply with Article III Section 2.4.2b.

**Due to the nature of the comments contained herein, additional comments may be forthcoming upon receipt of the required information.**



## MEMORANDUM

DATE: April 24, 2015

TO: Jose Larranaga, Development Review Team Leader

FROM: Mathew Martinez, Development Review Specialist

VIA: Vicki Lucero, Building and Development Services Manager  
Wayne Dalton, Building and Development Services Supervisor

FILE REF.: CDRC CASE #MPZ/PDP/DP/15-5130 Ashwin Stables

---

### **REVIEW SUMMARY**

#### **ARCHITECTURAL, PARKING, LIGHTING, AND SIGNAGE:**

The Referenced Project has been reviewed for compliance with the Santa Fe County Land Development Code. The request is for Master Plan Zoning, Preliminary and Final Development Plan to allow an Equestrian Facility on 7.746 acres. The subject property is located at 10 Heartstone Drive, south of Tano West.

#### **PARKING:**

The Applicant has provided an existing Parking Plan which includes 10 parking spaces. The Applicant shall comply with all parking requirements within Article III, Section 9 (Parking Requirements). Staff has determined that the Parking element of this Application complies with Article III, Section 9 (Parking Requirements).

#### **ARCHITECTURAL:**

The Applicant has submitted Building Elevations of existing structures. No new structures are proposed with this Application. The elevations of the existing structures range from 10 feet 10 inches to 24 feet in height. Staff has determined that the Architectural element of the Application complies with Article III, Section 2.3.6b of the Land Development Code.

#### **SIGNAGE:**

The Applicant does not propose any signage in this Application. Any future signage shall comply with Article VIII (Sign Regulations).

NBD-49

**LIGHTING:**

The Applicant does not propose any outdoor lighting in this Application. Any future outdoor lighting shall comply with Article III Section 4.4.4h (Outdoor Lighting Standards).

**Due to the nature of the comments contained herein, additional comments may be forthcoming upon receipt of the required information.**

## MEMORANDUM

**DATE:** May 27, 2015

**TO:** Jose Larranaga, Commercial Development Case Manager

**FROM:** John Lovato, Terrain Management

**VIA:** Penny Ellis-Green, Land Use Administrator  
Vicki Lucero, Building and Development Services Manager  
Wayne Dalton, Building and Development Services Supervisor

**FILE REF:** CDRC CASE # MP/PDP/FDP 15-5130 Ashwin Stables

---

### **REVIEW SUMMARY**

The above referenced project has been reviewed for compliance with the Santa Fe County Land Development Code and Ordinance 2008-10 Flood Damage Prevention and Stormwater Management. The request is for Master Plan, Preliminary and Final Development Plan approval to allow for a barn, hay barn, 2 stables, covered arena, horse barn, and residence totaling 16,542 square feet on a 2.71 acre tract.

### **Terrain Management**

The site contains slopes from the north to the south less than 0-20%. All cut slopes are less than 2:1 and all fill slopes are 3:1. The request is in conformance of Article VII, Section 3.4.2 (Terrain Management Plan).

### **Storm Drainage and Erosion Control:**

The Applicant's proposal illustrates existing conditions and a proposed Grading and Drainage plan. The required amount of retainage needed for runoff is 4,615 cubic feet. The amount of retainage provided is 25,000 cubic feet. Therefore, the proposal is in conformance with Article VII, Section 3.4.6 and Ordinance 2008-10 Flood Damage Prevention and Stormwater Management.

NBD-51



April 16, 2015

Jose Larranaga  
Development Review Team Leader  
102 Grant Avenue  
Santa Fe, NM 87504

Dear Mr. Larranaga:

On behalf of Altshuler LLC., I hereby authorize James W. Siebert & Associates to submit application documents, attend meeting with Land Use staff and present to the CDRC and BCC my request to rezone and subdivide the property located at 10 Heartstone Drive.

Sincerely,



Don Altshuler

NBD-53

CERTIFICATION OF POSTING

I hereby certify that the public notice posting regarding Land Development  
Case # 15-5130 was posted for 21 days on the property beginning  
the 24 Day of June, 2015.\*\*

Abon Alcala  
SIGNATURE

\* Photo of posting must be provided with certification

\*\* **PLEASE NOTE:** Public notice is to be posted on the most visible part of the property. Improper legal notice will result in tabling of your case at the public hearing. It is the applicant's responsibility to ensure that the notice is on the property for the full 21 days.

STATE OF NEW MEXICO }  
COUNTY OF SANTA FE }

The foregoing instrument was acknowledged before me this 24 day of  
June, 2015, by Don Altshuler.

Victoria M Dalton  
NOTARY PUBLIC

My Commission Expires:  
5/23/19

SEAL



NB0-54

## PUBLIC NOTICE

Notice is hereby given that an application has been filed with Santa Fe County for **MOSELER PUMP ZONING, PRELIMINARY & FINAL DEVELOPMENT PLAN APPROVAL TO ALLOW AN EQUESTRIAN ESCUELO ON 2.71 ACRES, ±**

Name of Applicant: DONALD SHULLER  
Address of Request: 10 MARKETSTONE DRIVE  
Legal Description: Section 4, Township 17 North, Range 1 West, NMPM Santa Fe County, New Mexico  
A Public Hearing will be held at the Old Santa Fe County Courthouse, corner of Palace and Grant Avenues, Santa Fe, New Mexico on ~~July 16~~ **July 20** at 4 pm before the County Development Review Committee.  
Further information can be obtained by contacting the Land Use Department, P.O. Box 276, Santa Fe, NM 87504  
Phone (505) 966-6225. Development Permit # 15-1420

NBO-55



NBD-56



THE SANTA FE  
**NEW MEXICAN**  
Founded 1849

LEGAL # 98644

CDRC CASE #  
Z/PDP/FDP 15-5130  
Ashwin Stables

Notice is hereby given that a public hearing will be held to consider a request by James W. Siebert and Associates, agent for Don Altshuler, for Master plan Zoning, Preliminary and Final Development Plan approval to allow an Equestrian Facility on 2.71 acres ±. The property is located at 10 Hearstone Drive, within Section 4, Township 17 North, Range 9 East, (Commission District 2).

A public hearing will be held in the County Commission Chambers of the Santa Fe County Courthouse, corner of Grant and Palace Avenues, Santa Fe, New Mexico on the 16th day of July 2015, at 4 p.m. on a petition to the County Development Review Committee.

Please forward all comments and questions to the County Land Use Administration Office at 986-6225.

All interested parties will be heard at the Public Hearing prior to the Commission taking action.

All comments, questions and objections to the proposal may be submitted to the County Land Use Administrator in writing to P.O. Box 276, Santa Fe, New Mexico 87504-0276; or presented in person at the hearing.

Published in The Santa Fe New Mexican on June 25, 2015

NB0-57

7014 1200 0001 4192 1377

**U.S. Postal Service™**  
**CERTIFIED MAIL™ RECEIPT**  
 (Domestic Mail Only; No Insurance Coverage Provided)

For delivery information visit our website at [www.usps.com](http://www.usps.com)

**OFFICIAL USE**

Postage	\$ Ashwin Stables	Postmark Here
Certified Fee	CDRC	
Return Receipt Fee (Endorsement Required)		
Restricted Delivery Fee (Endorsement Required)		
Total Postage		
The Akard-ward Trust 9 Crossroads Court Santa Fe, NM 87507		
Sent to		
Street, Apt. No. or PO Box No.		
City, State, Zi.		
PS Form 3800, August 2006		See Reverse for Instructions

7014 1200 0001 4192 1384

**U.S. Postal Service™**  
**CERTIFIED MAIL™ RECEIPT**  
 (Domestic Mail Only; No Insurance Coverage Provided)

For delivery information visit our website at [www.usps.com](http://www.usps.com)

**OFFICIAL USE**

Postage	\$ Ashwin Stables	Postmark Here
Certified Fee	CDRC	
Return Receipt Fee (Endorsement Required)		
Restricted Delivery Fee (Endorsement Required)		
Total Postage		
George Chapell 12 Brooks Way Santa Fe, NM 87508		
Sent to		
Street, Apt. No. or PO Box No.		
City, State, ZIP		
PS Form 3800, August 2006		See Reverse for Instructions

7014 1200 0001 4192 1360

**U.S. Postal Service™**  
**CERTIFIED MAIL™ RECEIPT**  
 (Domestic Mail Only; No Insurance Coverage Provided)

For delivery information visit our website at [www.usps.com](http://www.usps.com)

**OFFICIAL USE**

Postage	\$ Ashwin Stables	Postmark Here
Certified Fee	CDRC	
Return Receipt Fee (Endorsement Required)		
Restricted Delivery Fee (Endorsement Required)		
Total Post		
Key & Jean Jones 143 Graythorn Dr. Santa Fe, NM 87506		
Sent to		
Street, Apt. No. or PO Box No.		
City, State,		
PS Form 3800, August 2006		See Reverse for Instruc

7014 1200 0001 4192 1391

**U.S. Postal Service™**  
**CERTIFIED MAIL™ RECEIPT**  
 (Domestic Mail Only; No Insurance Coverage Provided)

For delivery information visit our website at [www.usps.com](http://www.usps.com)

**OFFICIAL USE**

Postage	\$ Ashwin Stables	Postmark Here
Certified Fee	CDRC	
Return Receipt Fee (Endorsement Required)		
Restricted Delivery Fee (Endorsement Required)		
Total Post		
Heartstone HOA C/O Doug Dickenson 2 Plano Arbolito Santa Fe, NM 87506		
Sent to		
Street, Apt. No. or PO Box No.		
City, State,		
PS Form 3800, August 2006		See Reverse for Instruc

**SENDER: COMPLETE THIS SECTION**

- Complete items 1, 2, and 3. Also complete item 4 if Restricted Delivery is desired.
- Print your name and address on the reverse so that we can return the card to you.
- Attach this card to the back of the mailpiece, or on the front if space permits.

1. Article Addressed to:

Heartstone HOA  
C/O Doug Dickenson  
2 Plano Arbolito  
Santa Fe, NM 87506

Ashwin Stables CDRC

2. Article Number  
(Transfer from service label)

7014 1200 0001 4192 1391

**COMPLETE THIS SECTION ON DELIVERY**

A. Signature  
 Agent  
 Addressee

B. Received by (Printed Name)  
 D S DICKENSON

C. Date of Delivery  
 6/27/05

D. Is delivery address different from item 1?  
 If YES, enter delivery address below:  Yes  No

3. Service Type  
 Certified Mail  Express Mail  
 Registered  Return Receipt for Merchandise  
 Insured Mail  C.O.D.

4. Restricted Delivery? (Extra Fee)  Yes

NAD-58

To:

County Development and Review Committee

The Board of County Commissioners

Jose Larranaga

Subject:

10 Heartstone Dr. Santa Fe, NM 87506 Rezone from residential to commercial

AKA: Ashwin Stables

Our concerns:

- Bringing commercial zoning to a residential neighborhood that may open the door for more commercial zoning.
- The project for review has started from a privately owned barn then progressing to a leased facility, now asking for commercial zoning. Concerns here are based on the barn's illegal history that a commercial zoning permit should not be granted because it has already been operating in this way. That what has been historically a residential area should introduce commercial zoning, simply because the owner wants to be able to lease his barn to a horse trainer for profit. Does 9 years of illegality justify changing residential permitting to commercial, in a quiet residential area, and who is required to police this, since they have historically been doing things they shouldn't? This is not a case where the owner was unaware of the law; he has been a very successful real estate developer. It's not a case of ignorance, and should not be granted a rezone permit when they have been operating with intentional violation of the law.
- Water usage. The proposed project rezone lists usage of .226 (73,544 gallons) per year for trainer, clients, horses, etc. based on 12 horses in the chart, but the description lists 10 horses for clients and 4 of the trainers, with potentially 2 more for Heartstone development residents, totaling 16. The barn proposal calls for 12 limit, yet shows stalls for 16 and does not list additional usages of water beyond 12 animals in addition to uses not listed such as watering the arena, or washing 16 horses.
- Traffic concerns. The plan makes no mention of added horse shows or clinics that may take place. Parking is already limited with little parking for additional visitors that may require parking on the main drive. The main drive is a 2-lane road with the barn located close to the entrance from Tano west.
- Most clients will be coming in from outside of the development to work with the one trainer listed in the proposal, but the plan makes no mention of any other trainers that have been seen working with clients at the facility, or the



NB10-59

traffic of the farriers, vets, and any temporary help needed for clinics held, or horse shows.

- In addition to the traffic concerns, we are concerned about any usage of horse haulers. An eighteen-wheeler woke us up at 1 a.m. rattling our walls and windows where it was seen backing up to the barn. This is unreasonable in a residential neighborhood.
- In conjunction to the parking concern, the plan makes no mention of trailer parking. Currently horse trailers are parked across the road on the far left side where there are also additional stalls in use.

#### Closing

After less than 8 months as a resident of Canterbury we have learned of an unlicensed barn that has been in existence for over 9 years and then just recently Don Altshuler, the developer and owner of the barn, decides he wants to put in a new road beside our property without approval from the county. How many more times is the county going to allow this man to cheat the system? We certainly had to abide to many building codes and neighborhood covenants. It never entered our minds to try to cheat on any rules. Why should this developer continue to be allowed this course of action?

Sincerely,

Handwritten signatures of Steve and Tamara Rymer. The signature on the left is 'Steve Rymer' and the signature on the right is 'Tamara Rymer'.

Steve and Tamara Rymer  
36 Heartstone Dr.  
Santa Fe, NM 87506

NBD-Geo

## Jose Larranaga

---

**From:** Bernard <bernardh@cybermesa.com>  
**Sent:** Thursday, July 02, 2015 11:14 AM  
**To:** Jose Larranaga  
**Subject:** Commercial Zoning in the Tano Road area

To: Mr. Jose Larranga  
From: I. B. Hirsch, Esq. and Deborah Schreifels (4 Plano Arbolito, 87506)  
Subject: Rezoning of Ashwin Farms

My wife and I are residents of the Heartstone development which abuts the property known as Ashwin Farms currently being considered for rezoning for commercial use. Unfortunately, we will be out of town when the official hearing on this application is held and, therefore, wish to express our views about this issue at this time. They are as follows:

1. We believe that any rezoning that changes the residential character of this area benefits no one other than the applicant. Commercial usage in a residential area that does not service the residents of that area has no positive effects and, more than likely, will have a negative impact on residential property values and the peace, quiet, and tranquility that currently exist here. Many years ago, I lived in a residential area that was relatively close to a commercial (business) zone. There was the constant disturbance to local residents by the sights and sounds of commercial activity. The area was excessively trafficked during all hours of the day. Horns, lights, and noise were constant irritants. The potential for a similar situation is not what anyone needs or wants here.
2. In most instances, municipalities and government entities rezone areas for commercial use because there is a need for such commercial development. Services and businesses in these commercial zones are planned and developed, usually in some form of comprehensive master plan, to serve the surrounding residential area. The intent is to create areas with a wide variety of commercial establishments allowing for convenient day to day shopping and services. Often, jobs are also created. That is not the case here. Commercial zoning of this area would benefit none of the adjacent residents.
3. Further, it is our understanding that this zoning change is being sought because changes have already been made that violate the existing zoning code. These changes were obviously made without the consent of the county or without the knowledge or even consideration of the nearby property owners. One cannot help but wonder whether or not such actions will take place in the future; making changes and by-passing any process or rules the county puts in place if this rezoning is approved.
4. Granting such a change in zoning would also seem to be legitimatizing that which is already illegitimate. Rather than the rewards of a zoning change, we would think that if there were clandestine and arbitrary actions in the past that violated codes, penalties should be incurred.

5. We have been advised that it would be necessary for the applicant or any future owner of this property to go to the county for any usage change. Past experience, however, shows that not everyone adheres to the rules and that, as we indicated before, changes that violate existing zoning restrictions appear to have already been made without county approval or knowledge. Therefore, there is no guarantee that the same modus operandi would not be followed in the future.
6. Lastly, we have also been advised that the county does not have the resources to monitor whether or not any future changes are clandestinely made. If they do not, the burden of making certain that the applicant is adhering to “the letter of the law” will fall on nearby homeowners. This places an unfair responsibility of continued vigilance on local residential property owners.

It would appear from the foregoing that the logical solution to this issue would be to deny the application and maintain the existing zoning restrictions. There is only one beneficiary of this rezoning and acting in favor of this change would be to reward alleged past transgressions and without any guarantees that whatever restriction is now being imposed will not be violated in the future. Moreover, such rezoning provides no economic or any other benefit to the residents of this community and, if anything, would be detrimental to the local homeowners. We are hopeful that whoever is responsible for making this decision would strongly consider the rights of these home owners and would strive to make certain that the residential character of this community is maintained.

## Jose Larranaga

---

**From:** Barry Schrager <barry8226@sbcglobal.net>  
**Sent:** Thursday, July 02, 2015 11:28 AM  
**To:** Jose Larranaga  
**Subject:** protest

Dr Barry Schrager  
21 Via Diamante  
Santa Fe N.M.  
87506

Mr. Jose Larranaga  
Development Review Team Leader

I would like to formally protest against application 12-5130 to make a zoning change from residential to commercial development at the Ashwin Stables, 10 Heartstone Drive, Santa Fe, New Mexico 87506. I am a resident of Santa Fe County and reside in the Heartstone Community off of Tano Road. I am on the Board of Directors of the Home Owners Association. My property would be effected if this zoning change is passed. The value of my home would decrease due to my proximity to a commercial zone.. The Northwest area of Tano Road has no commercial zoned property. My wife and I moved to this located because we understood that there is no commerce in the area. We enjoy being away from the commercial locations of the city and the traffic patterns that exit. No one in our Heartstone community is using the Ashwin Stables so this property does not even serve the residents. If this passes, it would increase the use of the common well water and take away the rural setting of our community as well as bring more traffic and create more repairs to our roads.

This proposed commercial area benefits only Don And Jean Atshuler who plan to sell the property as soon as the zoning passes. They have no concerns for there neighbors that border on this property for them; it is strictly a business proposition. **They have been in violation of the zoning rules for years and are now trying to change the laws so they can profit from it.** They failed to disclose the history of their business venture while they were building and even before they submitted the application to the County Offices and have caused much distress in the community that borders Ashwin Stables.

Sincerely,  
Dr. Barry Schrager

**Sandra Bruce & Wendy Stresau**

18 Via Diamante • Santa Fe, New Mexico 87506

Date: July 2, 2015

Jose E. Larranaga  
Building & Development Services  
Santa Fe County  
108 Grant Ave.  
Santa Fe, NM 87504

Dear Mr. Larranga:

We are residents of the Heartstone development. We object to changing the zoning from residential to commercial zoning for the Equestrian Facility located at 10 Heartstone Drive, within Section 4, Township 17 North, Range 9 East, (Commission District 2).

Since this area (and the large area around Tano Road) is exclusively a residential area, we are not in favor of allowing commercial zoning in this area.

In addition, we are concerned that the current and potential future owners of this property and the associated equestrian boarding and training business may have additional, increasingly negative impact on the community including: increased traffic, noise, air pollution and water consumption.

Sincerely,



Sandra J. Bruce



Wendy R. Stresau

NB0-64



## Jose Larranaga

---

**From:** Audrey Goldings <asgmd2@sbcglobal.net>  
**Sent:** Thursday, July 02, 2015 4:23 PM  
**To:** Jose Larranaga  
**Subject:** re: rezoning of Ashwin Stables to commercial real estate

Dear Mr. Jose Larranaga, Development Review Team Leader :

I am a resident of Heartstone Homeowners Association.

re:rezoning of Ashwin Stables to commercial  
When we bought our property we purchased it thinking that it was a residential quiet area apart from any commercial business. The whole community was not informed that there was **actually a commercial business being conducted by the Altshulers who were using a residential-equestrian zoned area to build it illegally, unknown to us and the county or Santa Fe. NONE of the residents in the area have ever used the stables** so this business grew as an enterprise **solely to benefit the Altshulers** Many of us do not welcome the deceit of their endeavor to us or the county of Santa Fe these years and do not wish to "oh well, they already did it so just let them sell it to someone else who might continue to grow the business without our knowledge." Who knows how much water these horses have used since it is unmetered? One resident reports the building of a road onto the property and an 18 wheeler carrying horses riding by at 1 AM.

The Altshulers have also threatened us and stated if they can't sell the Stables or keep the business they will let the property deteriorate. I do not like being threatened this way. Please do not reward them and penalize the homeowners who live near these stables and did not know the expansion that was taking place behind our ( and the county's) backs.

Audrey Stein Goldings, M.D.

21 Via Diamante

Santa Fe, New Mexico 87506

505- 982- 4405

## Jose Larranaga

---

**From:** Tony Buffington <tbuffington@huntconsolidated.com>  
**Sent:** Tuesday, July 07, 2015 7:26 AM  
**To:** Jose Larranaga  
**Cc:** 'Nancy Berry'; 'Tony Buffington'  
**Subject:** RE: Ashwin Stables Zoning Change Application 15-5130

Mr. Larranaga,  
I have noticed that my earlier email incorrectly cited the zoning change application as case number 12-5130 vice 15-5130. The error has been corrected in the below email.

Kind Regards,  
Tony Buffington  
Nancy Berry

---

**From:** Tony Buffington [mailto:tdbuffington@att.net]  
**Sent:** 07/05/2015 10:27 AM  
**To:** joselarra@santafecountynm.gov  
**Cc:** 'Nancy Berry'; Tony Buffington  
**Subject:** Ashwin Stables Zoning Change Application 15-5130

Tony Buffington  
Nancy Berry  
6 Plano Arbolito  
Santa Fe, NM 87506

July 5, 2015

Mr. Jose Larranaga  
Development Team Leader  
Building and Development Services  
Santa Fe County

RE: Zoning Change Application 15-5130

Dear Mr. Larranaga:

We own a home at 6 Plano Arbolito, in the Heartstone community, which we currently occupy on a part-time basis. Our plans are to begin living there full time in 2017. We wanted to write and express our views about the application for Ashwin Stables zoning change 15-5130 - changing the property in question from Residential use to Commercial use.

>>

>> We object to this change for the following reasons:

- In our view granting the change simply opens the entire community up to future Commercial development. No matter the supposed restrictions placed on the current request - the change creates a Commercial Neighborhood (CN) overlay in an area currently zoned Residential Estate (RES-S). The first step down a road we have no interest in taking and a change which benefits

*NBD - CeCe*

no one in the community other than the applicant and operator of the stables - past, present and future.

>> - We believe that having Commercially zoned property within the boundaries of the Heartstone and Canterbury residential communities will lower the property values in those communities, as well as those of our neighbors in the Tano Road area.

>>

>> -We believe that a commercially zoned business would inevitably diminish the quiet enjoyment of the homes in the area. Increased traffic coming into our residential neighborhood will place increased demands on an infrastructure designed to support a residential neighborhood. There will no doubt be more noise, more cars on our roads, more strangers becoming aware of and entering our neighborhood.

>>

>> -It is especially significant to Heartstone residents that we not have a commercially zoned business at the very entrance to our neighborhood. This area is near our mailboxes and increased traffic at the Stables has the potential to create a bottleneck at the entrance to our neighborhood. When a Heartstone or Canterbury resident wants to sell their home, perhaps for medical reasons or to be closer to one's children, it will be a commercial property that will create the first impression potential buyers have of our community. This will no doubt result in slower sales and lower resale prices.

>>

>> -This is primarily a retirement community and as we and our neighbors age in place, concerns of security and neighborhood safety will only become more of a priority. As elderly citizens, we will increasingly become vulnerable to the presence of strangers in the neighborhood and we will have no real way to know if cars with strangers are there for a lawful purpose. Many neighbors walk on Heartstone Drive for exercise, and increased road traffic would decrease the safety of the road for resident walkers and joggers.

>>

>> -The stable has been operating for some time with an illegal number of horses, and for the County to reward a landowner who has been quietly violating the law with a convenient transition to commercial status, prompted by an agreement to sell the property which is already in place, is unwise public policy and sets a dangerous precedent.

>>

>> -Don and Jean Altshuler do not appear to understand the potential for detrimental impact to their neighbors in a change to commercial zoning and the likely evolution of the Ashwin Stables business when it is sold to a third party without a residential interest in the Heartstone Community. In a July 1 letter to the Heartstone Board and Community Members, Jean Altshuler stated, "Don and I live in a manner that has irked our neighbors in that while we recognize the rules and laws, we also tend to turn a blind eye when some convenient infraction is apparent but is not hurting anyone." Apparently the current violation of the existing zoning law(s) is a convenient infraction in their minds. Given that and the County's limited code enforcement resources any representations or guarantees made by the Altshulers about what will or won't happen in the future cannot reasonably be relied upon by Heartstone residents. Even if the county limits this to equestrian use, could our future include a retail store selling equestrian related items? We shudder at the prospect.

>>

>> -While it may be in the best interests of The Altshulers and the potential buyers of their business to have this zoning change granted, the residents of the Heartstone, Canterbury and Tano Road communities need the County to exercise leadership on this matter and protect the interests of the entire neighborhood and the common good.

>

> -Finally, and specifically as the request relates to use of the property for stabling horses, most of the open space around Ashwin Stables is owned by the Heartstone Homeowners Association (HHOA) as common area. Community property if you will. We are told, but have yet to officially confirm, that Mr. Altshuler retained an "equestrian easement" (the precise meaning of this is not clear to us) to this property when he organized the HHOA. It is our understanding the easement was retained in order to provide horse owning residents of the

Heartstone and Canterbury communities a place to ride their horses, whether the horses were boarded at Ashwin Stables or not. It is not known to us how granting the requested zoning change would impact this easement, but our assumption is that non-residents of the Heartstone and Canterbury communities would have the opportunity to ride horses throughout the HHOA's common area property. We object strongly to having complete strangers riding through our open spaces and a backdoor commercialization of community owned property. A commercialization of which has already taken place albeit illegally. This is not to mention the environmental impact brought on by the increased automotive traffic, demands on the aquifer due to increased water usage and potential damage to the open spaces as more horses are ridden through them.

>

> In summary, we believe the entire Heartstone, Canterbury and Tano Road communities' financial investment, quality of life and security will be negatively impacted by granting the requested zoning change. If the change is approved the list of commercial activities that could eventually be conducted at the existing site is virtually endless. What's next if the horse stabling business isn't successful? A storage facility? An equipment yard? A flea market? A recycling facility? What? The only party that benefits from the change is the applicant, Don Altshuler, as it does nothing positive for the community at large. Please deny requested zoning change application 15-5130.

>

> Kind Regards,  
> Tony D. Buffington  
Nancy Berry

NBD-68

July 3, 2015

To: Mr. Jose Larranaga  
Building and Development Services  
Santa Fe County

The first item to be discussed should be plain and simple. Why are you considering granting a commercial license in an area that is purely residential? There is no need for commercial property to exist in our Northwest area. Is there anything in your master plan for commercial use in a residential area? The resulting loss in property values could be extreme. The property in question was built for residential use and should remain as intended. The fact that has been used illegally as a commercial property should influence the county's decision since it establishes that the applicant has no problem with going outside of County regulations to pursue his end goals. It is clear signal that the County should should recognize the need to monitor, control and put fines and penalties in place on the actions of the applicant. This is primary in our objection and compiled on this is a proposal filled with erroneous assumptions as follows:

NBD-69

The project chart uses 12 horses for its criteria. The proposal itself shows there will be 16 horses. All the projections made for water usage etc are based on 12 horses and are therefore incorrect assumptions. Additionally, the projection does not show any provision for water usage for washing the horses. Most owners who ride - wash their horses after riding their horse, if not more often. Also, there two houses included in tract 1-A that are not shown. They appear to be rented as there are presently always cars parked in front - so, there will be additional water usage from the tenants of these two homes – which appear to be about 2000 + square feet in size and there is an additional apartment over the stalls making no less than three families using water for bath facilities and cooking etc. The outdoor arena area which is not shown on the map, as it is owned by the Heartstone Homeowners Assoc. (Mr Altshuler uses the land based on a granted easement) The arena(s) is/are used by many of the riders at the barn and is often watered to keep the dust down. Estimate of water usage for these arenas is difficult to estimate but it should be considered substantial. It should be noted there is also one additional assumption regarding the cistern to catch roof water. If there is not sufficient rain to keep it filled – where will the water come from? There is also an indoor arena that is

NBD-70

watered to keep it comfortable for riding.

Last, there are an additional 4 horse stalls, built a few years back, owned by Mr. Altshuler on a property adjacent to the barn property.

What is the outcome and usage for these stalls if not to have them for lease to the barn owner (tenant) as additional space for future growth.

They are currently being used as extra space for the barn and as a maternity ward for just born and young horses. As expected they are not included in any proposal. A summation of the water usage should be noted by the County: Total water usage could easily exceed 200,000 gallons per year and the well usage could exceed the estimates in the proposal by at least 40% if there is a continued drought not providing the the estimated cistern production. The water usage aspect of the proposal is a gross misrepresentation as the average size horse drinks 15 gallons per day. That equates to 16 horses drinking 77,000+ gallons a year. Most of the horses at the barn are large and some could drink up to 20 gallons a day, if ridden regularly. Add the rental homes, the apartment, the washing of horses, the watering of the arena (s) and barn facilities and you can judge the inordinate amount of water usage for this proposed, commercial barn.

The past shows the developer has moved outside of the zoning regulations previously with total disregard of the rules and procedures established by the County. Since this operation has operated illegally for years is not a reason for the County to now make it legal. The zoning change should be dis-approved and returned to its original use as residential stable. The number of stalls should be reduced and the owner can then be in a position to sell it as a residential property since he owns contingent land and this will cause him no financial hardship. The County should look at its Land Use Code and recognize that granting this commercial zoning change will affect many homeowners with major investments. No one gains from the proposed change other than the developer. Establishment of a commercial zone will leave the door open for others to establish other commercial enterprises in the middle of a residential neighborhood. Commercial zoning is designed to help and enhance an area not detract and reduce values. The other ramifications are the specifics for traffic (that are mis-estimated), the wear and tear on the road (Ashwin pays only 10 % of its upkeep) and the need for signage and lights that would detract from our residential area.

One more item – The classification of “other use” does not show a riding stable or training facility. Therefore one must refer to the NAICA code

NBD-72



which lists horse stables and training facilities as commercial establishments under # 713990. The list of commercial establishments that are within the code are frightening should one ever be applied for after a commercial license is granted in our area.

Please turn down the application and keep us a friendly, happy bunch of homeowners.

Sincerely,  
Don Miller  
45 Heartstone Dr.  
Santa Fe, NM. 87506

One more item that becomes important to a number of homeowners in our development. Regarding the split of the property – if there are to be 3 meters, one for each parcel, how will they be monitored, how will they be tamperproofed or locked and how will fines and penalties be established for overages? The community does not want the responsibility – does the County have the manpower and resources to handle the above?

NBD-74

## Jose Larranaga

---

**From:** Zev Guber <zevguber@icloud.com>  
**Sent:** Monday, July 06, 2015 10:39 PM  
**To:** Jose Larranaga  
**Cc:** Claudia Vianello; Doug Dickerson; Barry Schragger  
**Subject:** Fwd: Regarding the division and change of status of Ashwin Stables

Jose Larranaga  
Development Review Team Leader  
County of Santa Fe  
102 Grant Avenue  
Santa Fe, NM 87504  
[joselarra@santafecountynm.gov](mailto:joselarra@santafecountynm.gov)

Monday, July 6, 2015

Dear Mr. Larranaga;

We have been informed that this letter needs to reach you by July 7 to be included in the County Development Review Committee (CDRC) on July 11. Please confirm your receipt and inclusion of this letter for the CDRC review.

First a bit of history regarding the development of the Heartstone Community: My wife and I walked the property with Don and Jean Altshuler shortly after its purchase. Don was at that time planning a horse community of 5 and 10 acre lots. Our response was that we would only be interested in acquiring land if the property were developed on a basis similar to that of The Commons co-housing community on West Alameda. Don said that he doubted that that would be permitted in this area, but he would make a submission to the County for a variance that permitted 24 clustered homes on 60 acres. To his and our surprise, the County approved the plan shortly thereafter. On that basis, we purchased a property with the intention of building our future home here.

We also shared the community plan with close friends, the Slibers, who visited with their friends, the Dickersons. All three of these couples have since built substantial residences in the Heartstone community. Our friends, the Cohens, also visited and purchased a property on our recommendation. We then purchased an additional adjacent lot to offer friends or family. All of this is to say that we have caused the purchase of 5 lots from the Altshulers, an opportunity that we represented to all as the establishment of a residential intentional community. In our view, a change in status from a purely residential community to one having a commercial subdivision is a violation of the original understanding and agreement. As a matter of fact, had we been informed that the Altshulers might change the status of the property to allow commercial usage, we would not have purchased a lot nor encouraged friends to do so.

At present, in the context of being a residential community, we have no objection to the running of a boarding stable. The change in status to a commercial re-zoning, however, changes the original usage and agreement. It is in the view of this household that this change would happen at the expense of the community, as it sets a precedent that could be pointed to as the basis for further alteration. A well paid lawyer could make the case that since the Altshuhers were entitled to establish commercial ventures along Tano Road, so should the same rights be extended to others. The Heartstone and Canterbury communities would then be forever fighting further encroachment of our residential property rights. As such, we are emphatically against any zoning change tha

would allow commercialization of this area. In fact, what makes Tano Road so special is that it is purely residential. Let's keep it that way.

Sincerely,

Zev and Heidi Guber  
74 Heartstone Drive  
Santa Fe, NM 87506

NBD-76

## Jose Larranaga

---

**From:** Diane Lotti <diane.lotti@gmail.com>  
**Sent:** Monday, July 06, 2015 7:33 PM  
**To:** Jose Larranaga  
**Subject:** Zoning Change Application 12-5130

Diane Lotti  
69 Heartstone Drive  
Santa Fe, NM 87506

July 6, 2015

Mr. Jose Larranaga  
Development Team Leader  
Building and Development Services  
Santa Fe County

RE: Zoning Change Application 12-5130

Dear Mr. Larranaga:

I own a home at 69 Heartstone Drive, which is part of the Canterbury subdivision. I am writing to comment on the application for Ashwin Stables zoning change 12-5130, which would alter the property's use from Residential to Commercial.

I would like to be on record as opposing this change. I and everyone else that I have spoken to in this area moved here to enjoy the peace and solitude of a beautiful residential community. Although it has been stated that the "special permit" would be limited and would allow no further development, it does indeed set a dangerous precedent for further development in this and other surrounding neighborhoods. The private residential use which was originally approved should continue to be the only use allowed.

I appreciate your careful consideration of the comments and issues raised by my neighbors and others in the Tano Road area and trust you will not grant this change.

Sincerely,

Diane Lotti

**Jose Larranaga**

---

**From:** SCohen1110@aol.com  
**Sent:** Tuesday, July 07, 2015 12:33 PM  
**To:** Jose Larranaga  
**Cc:** zevguber@gmail.com  
**Subject:** Regarding the division and change of status of Ashwin Stables

Dear Sir:

As the owner of a lot in Heartstone Division (lot5) I strongly object to any change in the zoning for Ashwin Stables. It will lower property values, increase traffic problems, and change the environment of the division.

Thank you,  
Stanley L COhen

**Jose Larranaga**

---

**From:** Stan <scohen1110@aol.com>  
**Sent:** Tuesday, July 07, 2015 11:23 AM  
**To:** Jose Larranaga; Zev Guber  
**Subject:** Stables

I am strongly against the stables being rezoned as commercial !  
Stan Cohen

Sent from my iPhone  
Please excuse any typos!

Stan Cohen  
410-371-8000

**Jose Larranaga**

---

**From:** Jeaco1110@aol.com  
**Sent:** Tuesday, July 07, 2015 2:33 PM  
**To:** Jose Larranaga  
**Subject:** Heartstone Community's Proposed Zoning Change

Dear Mr. Larranaga,

We would like to add our voices to those of the Gubers and others in the Heartstone Community speaking *against* the prospective rezoning of the land currently occupied by the equestrian center, Ashwin Stables.

As stated by others, we, too, bought into the Heartstone community because it was developed and 'sold' as a special, *residential* community. We feel that any zoning changes which would allow for commercial enterprises will fundamentally change the community and create a slippery slope by way of a precedent for further commercial encroachments down the road.

We see no benefit whatsoever to the community at large if this re-zoning is granted. In fact, quite the opposite, and hope that you will agree.

Many thanks for your consideration,  
Jeanne & Stan Cohen

*"Asking a working writer how [s]he feels about critics is like asking a lamppost how it feels about dogs." ~ Christopher Hampton*



## Jose Larranaga

---

**From:** Ellen Collins <ellen@newmexico.com>  
**Sent:** Monday, July 06, 2015 3:20 PM  
**To:** Jose Larranaga  
**Cc:** TRA altshuler jean  
**Subject:** CDRC Case # Z/PDP/FDP Ashwin Stables

**Follow Up Flag:** Follow up  
**Flag Status:** Completed

TO: Jose Larranaga, County Development and Review Committee  
FROM: Ellen and Patrick Collins, 30 Tanoito, Santa Fe, NM

### IN SUPPORT OF CDRC Case # Z/PDP/FDP Ashwin Stables

In 1993, my husband and I built our house at 30 Tanoito. Tanoito is a private dirt road in the Tano Road neighborhood off Tano West.

Twenty-two years ago, our neighborhood was very rural -- Tano Road, Camino de los Montoyas and Tano West were all dirt roads, and there were several large horse properties in the area. A parcel of land just east of Camino de los Montoyas grazed a herd of black cattle. What is now the Heartstone/Canterbury/Ashwin Stables development was a pristine valley visible to us from Tano West as we traveled to and from the city.

In 2000, when the Altshulers applied for a development permit for their property, we were very interested in what was being proposed for the valley. We attended a neighborhood meeting to review and discuss the preliminary master plan. The primary concerns of Tano Road residents, including us, were: housing density, road access and traffic, water use, size and scope of the Ashwin Stables facility, character of the neighborhood and integrity of terrain, open space and trails. All of these issues were taken into consideration by the Applicants and the County, and were addressed and resolved to the general satisfaction of the neighborhood.

The houses are clustered on large lots with some architectural guidelines. Tano West was widened and paved by the Applicants, and in the past 12 or 13 years since the development was built, traffic from Heartstone/Canterbury has not increased noticeably on Tano West. Water use for the residences and the stables is permitted by the County and OSE in compliance with State and County policy and regulations. The Ashwin Stables were downsized from the original plans, and the facilities are very attractive and nestled into the Tano West ridge.

There have always been horses in the neighborhood, so an equestrian facility is in character with the area. There are large open spaces in and around the development, so the impression of the valley remains visible from Tano West.

We support the Special Permit for Equestrian Use with the various restrictions for the Ashwin Stables property as outlined in your email of July 2, 2015. We also depend on the County to consider what is best for each neighborhood when development applications are made to the CDRC and BCC. We do not expect that approval of the Special Permit for Ashwin Stables will set any precedent for unrestricted and inappropriate commercial development in the Tano Road residential neighborhood.



NBP-81

## Jose Larranaga

---

**From:** Nancy Drake <nancydrake@earthlink.net>  
**Sent:** Tuesday, July 07, 2015 4:34 PM  
**To:** Jose Larranaga  
**Subject:** CDRC Case #Z/PDP/FDP Ashwin Stables

Dear Mr. Larranaga:

We wanted to voice our support of granting Mr. Donald Altshuler Master Plan Zoning, Preliminary and Final Development Plan approval allowing an Equestrian Facility on 2.71 acres in conformance with Ordinance 1998-15 and Santa Fe Ordinance 1996-10, the Santa Fe County Land Development Code.

We believe all of the original and current concerns of our community/neighborhood were taken into consideration during the original application in 2000. These concerns in summary were: housing density, road access and traffic, water use, size, and scope of Ashwin Stables facility, character of the neighborhood, and integrity of terrain, open space and trails. The Altshuler's have consistently held the integrity of the Tano Road community as a high priority. They have been excellent stewards of the Heartstone and Canterbury developments in addition to the Ashwin Stables. We don't see the application for a special permit for sub-division as in anyway jeopardizing the original concerns of the Tano Road community.

Nor do we see the approval of the special permit in anyway harming the Tano Road community as the historical perspective of the Altshuler's stewardship has been consistently community centric. Please consider our position of approving the sub-division to be an asset to the community. Thank you for your consideration. We can be reached at 505-982-3732 should you want to contact us for any further information.

Kind regards,  
Nancy Drake  
Brent Feulner  
45 Tano Alto  
Santa Fe, NM 87506